

Research Paper



Monitoring vehicle noise and pollution with a smart IoT system

B Ravi Chandra¹, Thota Teja^{2*}, S.Thirupathaiah³, Syed Shashavali⁴, Patan Sohail Khan⁵

^{1,2*,3,4,5}G Pullaiah College of Engineering &Technology, Kurnool, Andhra Pradesh, India.

Article Info

Article History:

Received: 25 October 2022

Revised: 06 January 2023

Accepted: 13 January 2023

Published: 01 March 2023

Keywords:

Internet of Things (IoT)

Air Pollution Monitoring

Wireless Sensor Networks

Vehicle Emission Control

Carbon Monoxide Detection

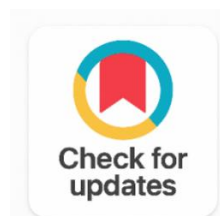

ABSTRACT

The ozone layer is deteriorating due to pollution in India and other parts of the world, which also greatly increases air pollution. The project's objective is to create a carbon monoxide detection system that can measure values in any application as well as track and monitor CO levels. The Internet of Things (IoT) connects things (physical objects like lights, phones, and cars) to the Internet by acting as a bridge connector to the current Internet infrastructure. Currently, only after receiving a fitness certificate (FC) from the RTO office can the vehicle's emissions be verified utilizing pollution control stations positioned across various cities. Health certificates for private vehicles are valid for 15 years, after which they must be renewed every 5 years. The fitness certificate is provided for two years and then renewed annually when it comes to vehicles. Until FC is fitted, this method prohibits us from identifying emissions brought on by car maintenance. Blynk is a cloud-based IoT analytics platform that allows you to gather, view, and analyze live data streams. This article focuses on using an MQ7 Gas sensor to prevent accidents caused by vehicle-generated carbon monoxide.

Corresponding Author:

Thota Teja

G Pullaiah College of Engineering &Technology, Kurnool, Andhra Pradesh, India.

Email: tejathota46784@gmail.com

Copyright © 2023 The Author(s). This is an open access article distributed under the Creative Commons Attribution License, (<http://creativecommons.org/licenses/by/4.0/>) which permits unrestricted use, distribution, and reproduction in any medium, provided the original work is properly cited.

1. INTRODUCTION

Environmental issues are becoming increasingly severe. Asthma attacks can be brought on by ground-level ozone and particulate matter from automobiles, buses, and trucks. More than half of the carbon monoxide in the atmosphere may be attributed to transportation. The health of people could be endangered by this carbon monoxide [1]. Air pollution increases the risk of cancer and contributes to chronic obstructive pulmonary disease (COPD) Pollution from vehicles [2] and trucks can also harm public

health in large metropolitan areas. One of the main sources of air pollution, accounting for 70% of all air pollution, is the release of harmful gases from moving cars. Monitoring pollution levels and identifying polluting vehicles are necessary for controlling air pollution. Cities may benefit from using the Internet of Things to track vehicle-related air pollution as well as collect and analyze information on the degree of pollution along various city routes [3]. Vehicle pollution is becoming a big issue in today's age. The incidence of automotive pollution has surged in recent years due to the exponential growth in the number of automobiles. The pollution created by vehicles disrupts the overall ecological balance that exists in nature because it is hazardous not only to humans but also to the entire environment. Vehicular pollution is the outcome of massive urbanization and population growth over the last decade. The automobile industry is becoming the backbone of economic development in emerging countries such as India, yet pollution created by autos is also a risk [4].

Gas sensor technologies are still in development and have yet to attain their full capability and application potential. Some systems are extremely accurate, but they are also prohibitively expensive for large-scale adoption. On the other hand, low-cost solutions can be implemented using a sensor network, and the issue of false positives may be reduced by using data multiplicity. A huge number of outputs from various sensors can be compared for a more accurate analysis. As a result, wireless sensor networks provide strong new methods for monitoring air quality. This experiment indicates a promising path for monitoring engine emissions, particularly CO₂ emissions. A gas sensor is used to detect motor vehicle pollution. This enables data tracking to be done cheaply and in real-time. The car's owner may easily determine the emission level ahead of time. The goal of this system is to reduce CO emissions in the atmosphere while also developing a tiny car pollutant-detecting device that could be installed on the vehicle itself. Sensors monitor the vehicle's smoke ratio, and the data is stored on the owner's phone, where it may be submitted to officials when they inquire about the vehicle's emissions report, such as when they visit a hill station.

Winters are no longer cold, and glaciers are melting faster than before due to changed weather patterns. It could be quite useful to have a carbon monoxide gas detector on hand. Knowing the proper level of pollution in the environment might help us plan for future problems and follow their sources to avert them [5].

Air and noise pollution are primarily brought on by transportation. Air pollution is responsible [6] for about 100000 premature adult deaths per year. 40 million people are exposed to air that exceeds WHO air quality guideline values for at least one pollutant in the 115 largest cities of the European Union (EU). The largest cause of climate change and the source of CO₂ emissions from fossil fuels is transportation. Due to a rise in transport volumes that exceeded improvements in the vehicle economy, transportation accounted for roughly 35% of all energy consumption in the 25 EU countries in 2004, leading to a 20% net increase in greenhouse gas emissions over the preceding decade. Automobiles produce sulfur dioxide, nitrogen oxide, and carbon monoxide. Using the internet of things, our suggested technique resolves this issue. The term "Internet of Things" (IoT) describes how physical objects, structures, cars, and other items are connected through the use of electronics, sensors, software, actuators, and network connectivity. This enables each object to gather and share data. To detect the pollutant level in this paper, semiconductor sensors were utilized.

1.1 Literature Survey

1.1.1 Minimization of CO & CO₂ from Two Wheeler Exhaust Gases

This article discusses a CO and CO₂ removal method for two-wheeler motorcycle exhaust emissions based on adsorption. The main objective of this paper [7] was to develop an adsorption model that can actively reduce contaminants from vehicle exhaust emissions while being economical and environmentally benign. In this instance, adsorption is carried out in a device that resembles an absorber and has a charcoal pad through which the exhaust gases pass. The cost of a product can be greatly decreased by using charcoal powder as an adsorbent. A fraction of emissions from two-wheelers can simply be added to the adsorption-based model. This device reduces CO₂ emissions significantly after adsorption from high-

output exhaust gases. In this situation, the performance of charcoal for Co₂ adsorption is estimated to be 20%.

1.1.2 Wireless Sensor Network for Real-time Air

This study outlines a methodology for monitoring ambient air quality in real-time. A machine-to-machine link connects the network's numerous scattered monitoring stations, which interact wirelessly with a backend server [8]. Real-time data collection from the stations is transformed into information that consumers can access via web portals and mobile apps via the backend server. Gas and weather sensors are installed in every building. Additionally, it has data logging capabilities and Wi-Fi connectivity. Four solar energy stations are installed over one Kilometer region as part of the system's experimental phase. Performance analysis and testing are done four months after the information collection period. India is the second-largest nation in the world by population. The nation's economy is growing quickly, and the transportation industry is essential to that growth. To detect and predict air pollution brought on by vehicles, this project makes use of an Arduino board, three gas sensors (MQ-2, MQ-7, and MQ-135), a GSM module, and a solenoid valve. The project is primarily an IoT one. The sensors pick up the gaseous pollution emissions from the car's exhaust. Depending on the threshold value, each sensor's corresponding led flashes to show how many hazardous gases it can detect. A warning message notifying the owner that his car has exceeded the BS IV safe emission standards is sent to him. After conceptualizing and analyzing it using a few IEEE papers and our ideas for preventing and controlling air pollution, we propose this method. An important aspect of this gadget dramatically lowers air pollution. The system stops/chokes the fuel flow from the fuel injector via the solenoid valve when the emission rate exceeds the specified threshold value. IoT is a developing field, and its technology aids in the automation of practically everything. As a result, we employ the benefits of this field to reduce a key environmental concern, air pollution. This approach has the potential to cause a paradigm change in the idea of preventing and reducing air pollution.

[9] Outline methods to monitor roadside air pollution and track vehicles that pollute above a certain level. Because of increased industrialization and urbanization, a large amount of particulate matter and harmful gases are created. Emissions are poorly controlled, and catalytic converters are rarely used. A critical issue that has existed for a long time is the increased use of automobiles.

There was an air quality monitoring system (AQMS) that adhered to IEEE standards. This procedure made use of the GSM wireless communication module. Real-time monitoring of dangerous gases like CO₂, CO, NO₂, and SO₂ was done using IoT sensor arrays. To pIoT the gas values it holds, the graphical user interface (GUI) was developed [10]. A global air emission monitoring program has been started with a three-phase air pollution surveillance system. Gas sensors, an Arduino IDE, and a Wi-Fi module are all included in this kit. Gas sensors are included in this IoT kit. Air quality data is collected by sensors placed in a town or region, which is then communicated in real-time to a server where it may be observed in a particular area [11].

[12] Has a low-cost geo-referenced air-pollution measuring system that is used as an early warning tool. The system is linked to a low-cost board with built-in Wi-Fi, allowing the data to be sent to the IoT cloud over MQTT protocol in real-time, allowing the geo-referenced information to be printed on an open access platform utilizing IOT.

1.2 Internet of Things

Many definitions of the Internet of Things (IoT) succinctly outline the technology's primary attributes and qualities as well as what users might expect when connecting things to the Internet. With the use of various data collection and networking technologies, distributed computing, such as cloud computing, and connecting physical and virtual domains, the Internet of Things is worldwide network architecture. The Internet of Things enables objects to communicate with one another, access information on the internet, store and retrieve data, and interact with users, resulting in smart, pervasive, and always-connected environments. Major technological advancements and developments are required to achieve such intelligence within computing environments. The experts believe that the IoT will soon take on a new structure and that the number of ubiquitous devices will skyrocket. According to the Internet of Things vision, individual everyday objects like cars, roads in transportation systems, pacemakers, wirelessly

connected pill-shaped cameras in digestive tracks for healthcare applications, refrigerators, or other household items like cattle can be fitted with sensors that can track useful information about these objects. Uniquely addressable objects and their virtual representations on a topology resembling a network are what the Internet of Things is supposed to be comprised of. Such objects might be able to connect to information about them or broadcast real-time sensor data about their condition or other important properties related to the object. The uniquely addressable items are connected to the Internet, and data about them can be transferred using the same protocol that links computers to the Internet. Due to their ability to interact with one another through feeling and communication, the objects can understand complex environmental behaviors and frequently enable autonomic reactions to challenging situations without human intervention. Pervasive and ubiquitous computing is made possible by the simultaneous automatic production of data from the environment by a huge number of devices.

The Future Internet is thought to include the Internet of Things (IoT). Research needs to concentrate on significant issues including identity, interoperability, privacy, and security for IoT technology to advance quickly. Future networks like 5G, big data, and cloud technologies must all be integrated with IoT [13].

1.3 Proposed System

We will show how the Internet of Things may be utilized to successfully address the problem of car pollution in this section. It is necessary to continuously evaluate the quality of the air to ascertain pollution levels and the presence of particular dangerous chemicals. This can be accomplished by using a variety of gas sensors, including those for carbon monoxide, sulfur dioxide, nitrogen dioxide, methane, and others. It is important to identify polluting cars so that appropriate action can be done.

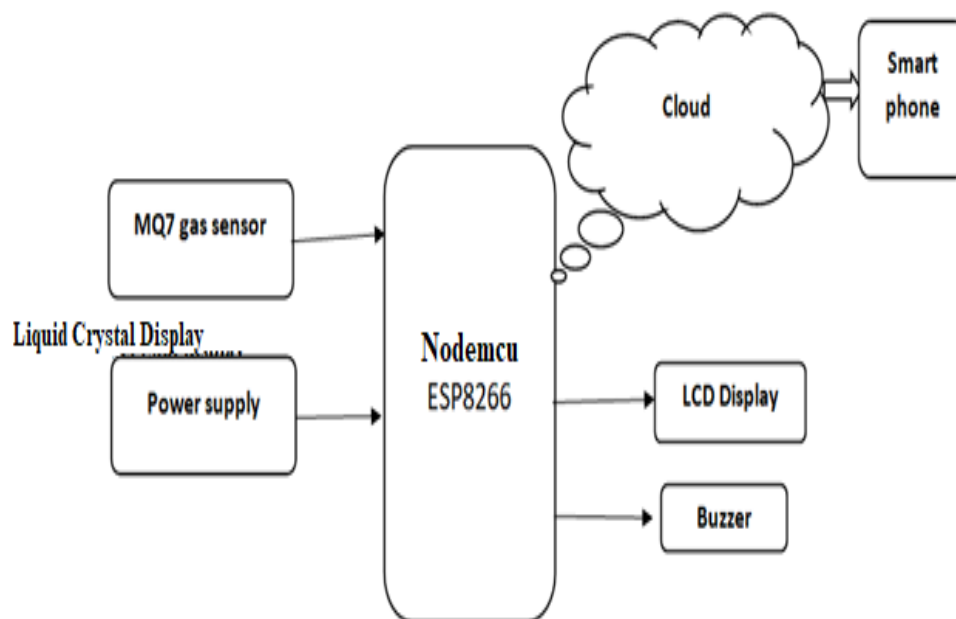

Figure 1. Block Diagram

a) Liquid Crystal Display

Displays that use liquid crystals LCD technology is a combination of the solid and liquid phases of materials. It is a 16x2 LCD electronic display module with 16 characters and 2 rows. A crystal liquid is used to form the viewable image on an LCD. This method is used to display graphics on laptop computers and other electronic devices. It contains 16 pins, including 8 input pins and a 5-volt external input voltage pin. It works by blocking light rather than creating light. It has the particular advantage of consuming less energy than an LED or a cathode ray tube.

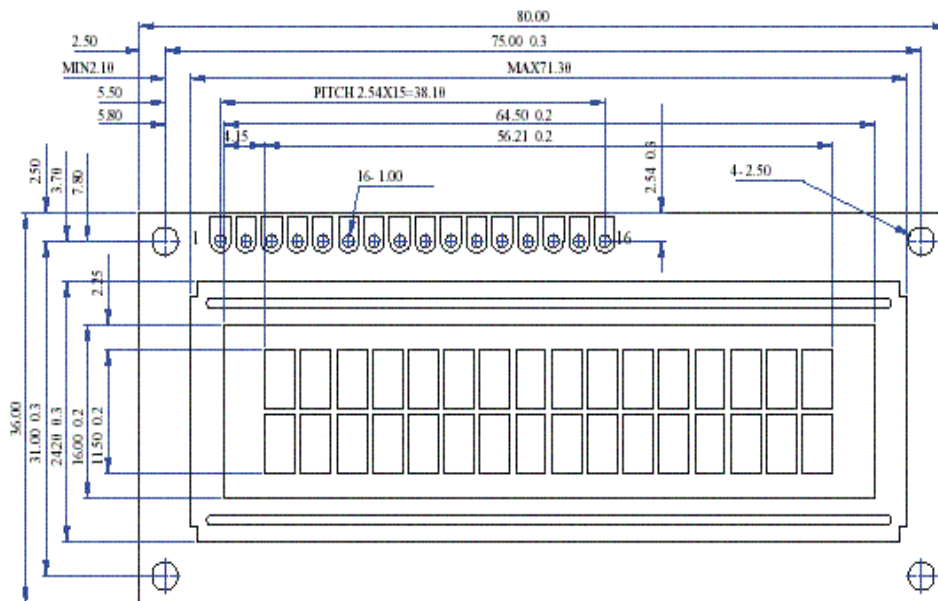

Figure 2. General Pin Diagram of LCD

b) Node MCU

The Node MCU- ESP8266 [14] is a Wi-Fi-capable microcontroller. It is an open-source Internet of Things platform. This little device connects microcontrollers to a Wi-Fi network and allows them to create simple TCP/IP connections using Hayes-style commands. The firmware is referred to as the Node MCU. This firmware makes use of the scripting language Lua. Its operating system and CPU are XTOS and ESP8266. It contains 128KB of memory and 4MB of storage. The controller's power is supplied via USB.

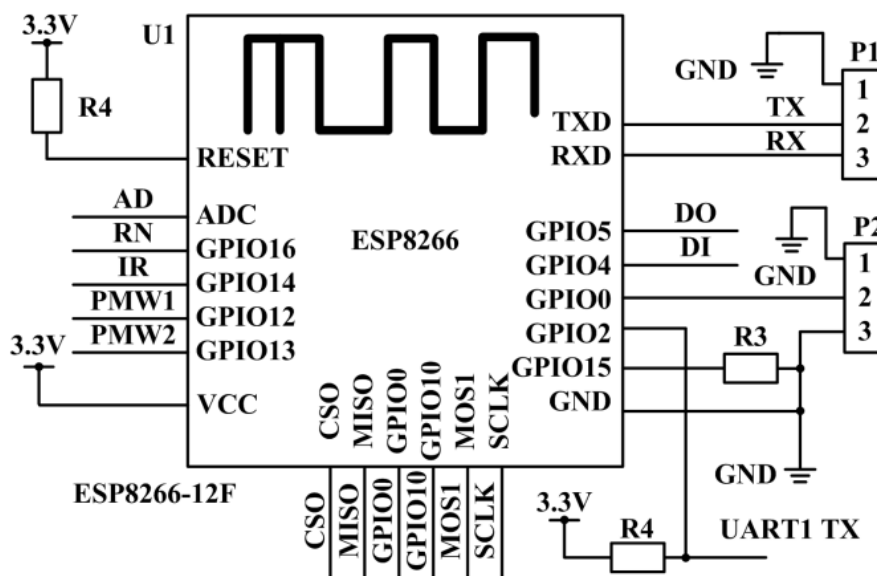

Figure 3. General NodeMCU ESP8266

c) MQ-7 Gas Sensors

Carbon Monoxide Sensor MQ-7 sensors [15] detect CO levels ranging from 20 to 2000ppm. The sensitivity of the sensor can be altered using a potentiometer. There are four pins (power, ground, digital and analog output). The production and carbon monoxide gas density are inversely related. Analog output is how the sensor data is presented. The sensitive chemical SnO₂ is used in the MQ135 gas sensor. When the concentration of a gas, which has lower conductivity in clear air, increases, so does its conductivity. It

reacts violently to fumes, ammonia, benzene steam, and hydrogen sulfide. It is used to identify gases with concentrations ranging from 10 to 10,000 ppm.

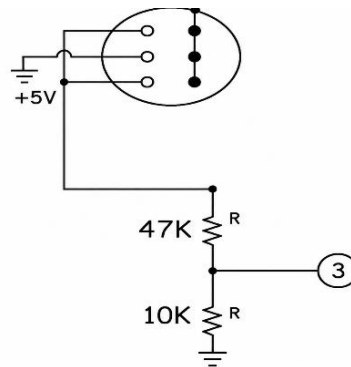

Figure 4. MQ7 Gas Sensor

d) Internet-of-Things

"Internet of Things" (IoT) A network of physical objects with electronics, sensors, software, actuators, and the internet that connect to exchange data is known as the Internet of Things (IoT). IoT enables objects to sense data and control them remotely.

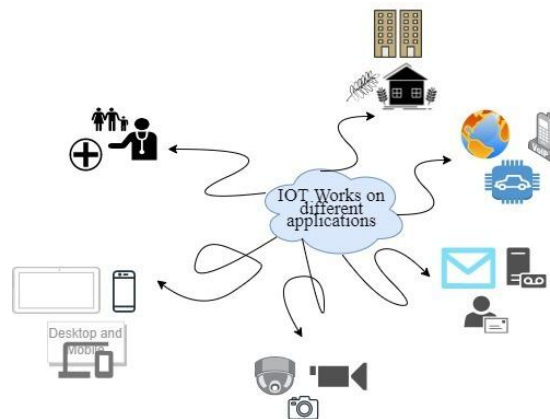

Figure 5. General Internet of Things

e) Buzzer

A buzzer also referred to as a beeper, is a mechanical, electromechanical, or piezoelectric audio signalling device (piezo for short). Common uses for buzzers and beepers include alarm clocks, timers, and confirmation of human input like a mouse click or keyboard.

We're making use of a piezoelectric buzzer. This buzzer generates sound by reversing the piezoelectric effect. The fundamental concept is the application of electric power across a piezoelectric material to produce pressure fluctuation or strain.

Regardless of the voltage fluctuation provided to the buzzer, it makes the same deafening sound. The 5v buzzer is used here.



Figure 6. Buzzer

f) CLOUD-Blynk

All this information is sent through the cloud to rescue systems, family members, etc.

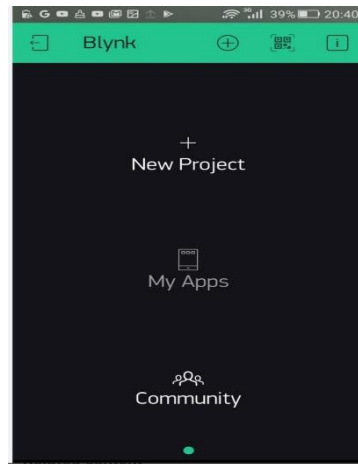

Figure 7. Blynk App in Mobile

1.4 Working Principle

Step 1: The Node MCU ESP8266 receives its output from the MQ7 Gas Sensor, which is installed in the vehicle's smoke outlet. The MQ7 Gas Sensor will measure the amount of carbon monoxide emissions in parts per million.

Step 2: The Blynk app stores the sensor data from our smartphone. The CO Value is saved and accessible at any time by date.

This graph shows the vehicle's carbon monoxide emissions over time.

X-axis: Data, Y-Axis: Co and SNO2 Value

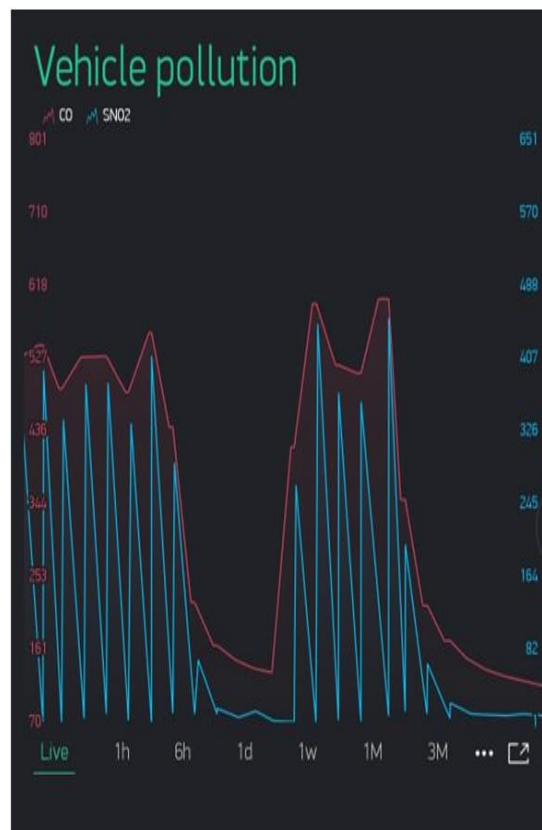

Figure 8. Blynk Cloud Data View in Smart Mobile

Step 3: If the CO emission level of the car exceeds the required threshold, Blynk receives the data and alerts the specified user through email. The owner of the car received a message. lethargy, and stagnant, stuffy air.

Step 4: Blynk is linked to the system. Blynk is a cloud-based IoT analytics platform that allows you to gather, view, and analyze live data streams. Blynk provides real-time visualizations of knowledge posted to Blynk by your devices. When there is no gas around, the sensor returns a value of 90, indicating that the emission level is safe up to 350 PPM and should not exceed 1000 PPM. When it exceeds the 1000 PPM limit, it causes headaches,



Figure 9. Results of Different Level of Ppm

Step5: Because of air pollution, we receive distinct graphical representations with various parameters.

Step6: The output devices are an LCD and a buzzer. The LCDs gas data in ppm (parts per million), and the buzzer sounds when the ppm exceeds a preset limit. Blynk is an IoT solution that is used to control Arduino, Raspberry Pi, and other similar devices through the internet. Blynk creates a digital dashboard on our smartphone that displays real-time air quality values for our local surroundings in this project.

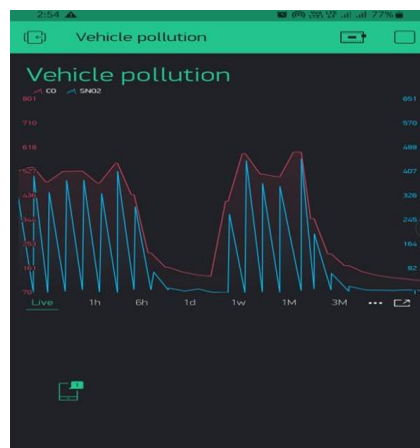

Figure 10. Result Displayed in Smart Mobile

1.5 Merits of the Proposed System

It aids in the real-time tracking of data.

- It is a cost-effective system.
- Unacceptable vehicle emissions can be cut by 98%.
- Without having to go to the RTO office, the car owner can quickly test the emission of their vehicle in advance.
- Additionally, by receiving the alarm message regarding the pollution level, the user can service the car beforehand. Provide wireless connection security.
- They instantly identify the presence of particulate matter or air pollutants in the air and alert users via text message. This enables the authorities to evaluate the circumstance and take the necessary action. Thanks to immediate notifications, managers can keep an eye on the air quality and handle the issue effectively.

1.6 Application

- With the use of air quality monitoring networks, it is possible to measure, operate, and predict how air pollution will change over time in various locations (urban areas, industrial areas, special nature conservation areas, etc.)
- Some stations use noise level meters or meteorological sensors to monitor the level of noise.

1.7 Future Scope

The proposed model takes carbon dioxide emissions into account. Whatever the case, harmful chemicals like carbon monoxide and SO_2 environment. The model will be used to keep track of the gases destroying our climate. CO outflow detection is now being done using this MQ7 sensor. This sensor can withstand temperatures of up to 70 °F. The entire assembly can be put into the exhaust system of a car. The model can be used in a range of businesses in addition to cars to evaluate dangerous compounds and lessen the air pollution these gases cause.

1.8 Final Setup of the Device



Figure 11. Final Setup of Device

2. CONCLUSION

To protect our environment, it is necessary to lessen the environmental pollution brought on by the gas emissions from vehicle exhaust, including carbon monoxide, hydrocarbons, and nitrogen oxide. The suggested approach gives the most effective technique to keep track of the gases that a vehicle's exhaust releases into the atmosphere, extending the life of the engine and reducing the environmental pollution. The suggested remedy is low-cost and easy to keep up. In the future, GPS might be used to track data and figure out how many gases are generated from driving cars in a certain location.

Acknowledgments

The authors have no specific acknowledgments to make for this research.

Funding Information

This research received no specific grant from any funding agency in the public, commercial, or not-for-profit sectors.

Author Contributions Statement

Name of Author	C	M	So	Va	Fo	I	R	D	O	E	Vi	Su	P	Fu
B Ravi Chandra	✓	✓	✓	✓		✓		✓	✓	✓	✓			
Thota Teja		✓	✓		✓									✓
S.Thirupathaiah	✓	✓		✓		✓		✓	✓			✓		
Syed Shashavali			✓				✓							
Patan Sohail Khan		✓		✓	✓		✓		✓		✓			✓

C : Conceptualization

M : Methodology

So : Software

Va : Validation

Fo : Formal analysis

I : Investigation

R : Resources

D : Data Curation

O : Writing - Original Draft

E : Writing - Review & Editing

Vi : Visualization

Su : Supervision

P : Project administration

Fu : Funding acquisition

Conflict of Interest Statement

The authors declare that there are no conflicts of interest regarding the publication of this paper.

Informed Consent

All participants were informed about the purpose of the study and their voluntary consent was obtained prior to data collection.

Ethical Approval

Not Applicable.

Data Availability

The data that support the findings of this study are available from the corresponding author upon reasonable request.



REFERENCES



- [1] Epidemiological Study on Effect of Air Pollution on Human Health (Adults) in Delhi", Environmental Health Management Series: EHMS/0112012, Central Pollution Control Board. Government Of India.
- [2] Z. J. Andersen et al., 'Chronic obstructive pulmonary disease and long-term exposure to traffic-related air pollution: a cohort study', American journal of respiratory and critical care medicine.
- [3] O. Raaschou-Nielsen, Z. Andersen, M. Hvidberg, S. S. Jensen, M. Ketznel, and M. Sorensen, 'Lung cancer incidence and long-term exposure to air pollution from traffic', Environmental health perspectives, vol. 119, no. 6, pp. 860-865, 2011. doi.org/10.1289/ehp.1002353
- [4] Postscapes: <https://www.postscapes.com/internet-of-things-protocols/>
- [5] M. Xiaofeng, G. Jianhua, C. Peng, and W. Chaozhong, 'An inexact bus departure frequency model for trafficpollution control', in International Conference on Transportation Information and Safety (ICTIS), Wuhan,China, 2015, pp. 25-28. doi.org/10.1109/ICTIS.2015.7232195
- [6] Air pollution and climate change [HTTP://www.euro.who.int/en/healthtopics/environment-andhealth/Transport-and-health/data-and-statistics/air-pollution-andclimate-change2](http://www.euro.who.int/en/healthtopics/environment-andhealth/Transport-and-health/data-and-statistics/air-pollution-andclimate-change2).

- [7] D. D. Lee and D. S. Lee, 'Environmental gas sensors"', IEEE Sensors J, vol. 1, no. 3, pp. 214-215, Oct. 2001. doi.org/10.1109/JSEN.2001.954834
- [8] S. Nihalkularatna and B. H. Ieee, 'Member, IEEE "An Environment Air Pollution Monitoring System Based on the IEEE1451 Standard for Low Cost Requirements', IEEE Sensors J, vol. 8, pp. 415-422, Apr. 2008. doi.org/10.1109/JSEN.2008.917477
- [9] B. Hunshal, D. Patil, K. Surannavar, M. B. Tatwanagi, and S. P. Nadaf, 'Vehicular pollution monitoring system and detection of vehicles causing global warming', Int J Eng Sci Comput, vol. 7, no. 6, 2017.
- [10] T. W. Ayele and R. Mehta, 'Air pollution monitoring and prediction using IoT', in 2018 Second International Conference on Inventive Communication and Computational Technologies (ICICCT), Coimbatore, 2018. doi.org/10.1109/ICICCT.2018.8473272
- [11] S. Dhingra, R. B. Madda, A. H. Gandomi, R. Patan, and M. Daneshmand, 'Internet of things mobile-air pollution monitoring system (IoT-Mobair)', IEEE Internet Things J, vol. 6, pp. 5577-5584, 2019. doi.org/10.1109/IJOT.2019.2903821
- [12] G. I. Agren and E. Bosatta, 'Nitrogen saturation of terrestrial ecosystems', Environ. Pollut., vol. 54, no. 3-4, pp. 185-197, 1988. [doi.org/10.1016/0269-7491\(88\)90111-X](https://doi.org/10.1016/0269-7491(88)90111-X)
- [13] P. Jianli, S. Paul, and R. Jain. "A survey of the research on future internet architectures." IEEE Communications Magazine, vol. 49, no. 7(2011) PP: 26-36. doi.org/10.1109/MCOM.2011.5936152
- [14] A. Skraba, 'Streaming pulse data to the cloud with Bluetooth LE or NODEMCU ESP8266', in 5th Mediterranean Conference on Embedded Computing (MECO), Bar, 2016, pp. 428-431. doi.org/10.1109/MECO.2016.7525798
- [15] J. A. Stankovic, 'Research directions for the internet of things', IEEE Internet Things J, vol. 1, no. 1, pp. 3-9, 2014. doi.org/10.1109/IJOT.2014.2312291

How to Cite: B Ravi Chandra, Thota Teja, S.Thirupathaiah, Syed Shashavali, Patan Sohail Khan. (2023). Monitoring vehicle noise and pollution with a smart IoT system. Journal of Artificial Intelligence, Machine Learning and Neural Network (JAIMLNN), 3(1), 43-54. <https://doi.org/10.55529/jaimlnn.31.47.58>

BIOGRAPHIES OF AUTHORS

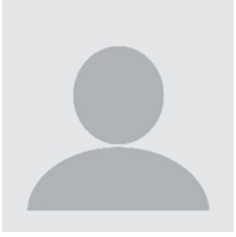
	<p>B Ravi Chandra, is an academic researcher and engineering professional affiliated with G Pullaiah College of Engineering & Technology. His research interests include Internet of Things (IoT), embedded systems, environmental monitoring, and wireless sensor networks. He worked on projects that developed smart pollution monitoring systems and vehicle emission control systems through the application of IoT technologies. He guides students while developing new solutions that protect the environment and improve smart transportation systems. Email: ravichandraece@gpct.ac.in</p>
	<p>Thota Teja, is a researcher from G Pullaiah College of Engineering & Technology with interests in IoT-based smart systems, pollution monitoring, and embedded applications. His work primarily aims to create affordable monitoring solutions that use NodeMCU and gas sensors and cloud technologies. He develops environmental monitoring systems which operate in real time to decrease vehicle emissions and enhance public safety. Email: tejathota46784@gmail.com</p>

	<p>S. Thirupathaiah, works at G Pullaiah College of Engineering & Technology where he teaches electronics and IoT applications and sensor monitoring systems. His research work has produced smart environmental monitoring systems and wireless communication systems and automation technologies. He has worked on various academic and technical projects which focus on developing new embedded technologies to enhance air quality monitoring and create sustainable engineering solutions. Email: tirupspk417@gmail.com</p>
	<p>Syed Shashavali, is a researcher and engineering enthusiast from G Pullaiah College of Engineering & Technology. He studies IoT systems and smart monitoring technologies and environmental sensing solutions and wireless communication systems. He developed vehicle pollution monitoring systems which use cloud platforms and gas sensors to monitor real-time data for environmental protection. Email: syedshashavali144@gmail.com</p>
	<p>Patan Sohail Khan, is affiliated with G Pullaiah College of Engineering & Technology and focuses on IoT-enabled environmental monitoring systems, embedded electronics, and automation technologies. His research work provides affordable and effective methods to detect pollution while developing intelligent transportation systems. He wants to create new technologies which enable environmental protection and smart monitoring systems. Email: sohailsohailkhan222@gmail.com</p>