

Research Paper



# Fault identification and protection of induction motor using PLC and SCADA

Nigam Bam Malla<sup>1\*</sup>, Ajay KC<sup>2</sup>

<sup>1,2</sup>Department of Electrical Engineering, IOE, Paschimanchal Campus, Tribhuvan University, Nepal.

## Article Info

### Article History:

Received: 11 October 2023

Revised: 28 December 2023

Accepted: 02 January 2024

Published: 18 February 2024

### Keywords:

Overload

Over Voltage

Under Speed

Thermal Overload

Fault Detection

Induction Motor Protection

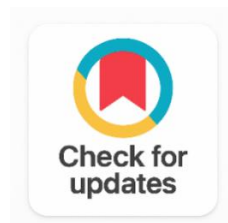

## ABSTRACT

If not properly maintained, AC induction motors are prone to malfunction. A protective system is put in place to keep an eye on the motor's performance under both normal and trip conditions to remedy this. The system may either modify the input voltage and current to restore normal performance in the event of faults like stator, rotor, bearing, or eccentricity issues or shut down the motor before irreparable harm is done. This guards against sudden shutdowns that could endanger employees, prevents unexpected motor failure, and reduces unforeseen costs. Due to their extensive industrial use, protecting induction motors from overvoltage, overcurrent, under-speed, and overheating is essential. Voltage and current relays, timers, contractors, and other traditional protection techniques are mechanical devices. Both computer-based and PIC-based techniques have fewer mechanical components, although the former needs analog-to-digital conversion cards while the latter does not display the observed electrical parameters. In this work, a PLC-based protection technique that does away with contractors, relays, and conversion cards is presented. It keeps an eye on system errors, motor voltages, currents, speed, and temperature while showing alerts on a computer screen. In comparison to conventional, computer, and PIC-based systems, experimental findings show that this PLC-based approach is more precise, efficient, and offers a safer and more visible environment.

### Corresponding Author:

Nigam Bam Malla

Department of Electrical Engineering, IOE, Paschimanchal Campus, Tribhuvan University, Nepal.

Email: [nigammalla@gmail.com](mailto:nigammalla@gmail.com)

Copyright © 2024 The Author(s). This is an open access article distributed under the Creative Commons Attribution License, (<http://creativecommons.org/licenses/by/4.0/>) which permits unrestricted use, distribution, and reproduction in any medium, provided the original work is properly cited.

## 1. INTRODUCTION

Induction motors, which are common electromechanical devices that convert electrical energy into mechanical power, are the foundation of many mechanical and industrial systems all over the world. Pumps, conveyors, machine tools, centrifugal machines, presses, elevators, and packaging machinery all use these sturdy machines. Induction motors are used in a variety of hazardous situations, including coal plant machinery, grain elevators, shredders, and petrochemical and natural gas plants. They are a flexible option for the majority of industrial processes thanks to their great dependability, low maintenance needs, and relatively high efficiency, as well as a wide power output range from a few watts to megawatts [1]. Despite their resilience, induction motors are prone to a number of problems in industrial environments. Motor failures that go unnoticed can result in severe motor damage and production shutdowns, which wastes raw resources and delays processing [2].

Electrical and mechanical issues can cause motor malfunctions. Bearing failures and rotor bar breaking can be brought on by mechanical stresses, which are frequently brought on by overload or abrupt load fluctuations. The most common cause of electrical failures is a bad power supply. Either constant frequency sinusoidal power supply or variable speed AC drives can power induction motors. The latter, however, increases the likelihood of problems because of induced bearing currents, high-frequency stator current components, and voltage/current imbalance. Long cable connections between the motor and the AC drive can also lead to motor overvoltage, which results in transient voltages caused by reflected wave waves. Short-circuits in the stator windings and total motor failure are possible outcomes of these electrical errors [3].

The most common induction motor failures include bearing failures, inter-turn short-circuits in stator windings, broken rotor bars, and end ring faults. About 40% of all motor faults are caused by bearing failures, while 33% are caused by inter-turn short circuits in the stator windings. Broken rotor bars and end ring faults make up around 10% of induction motor faults [4].

### 1.1 Problem Definition

Induction motors are susceptible to various faults during operation, and if left undetected, these faults can result in motor failures. These faults can be categorized into two primary groups: electrical faults and mechanical faults.

Several conditions can lead to induction motor failure, including: (a) Thermal Overload: Excessive heat buildup due to overloading or inadequate cooling; (b) Phase Fault: Imbalance in the three-phase power supply causing uneven current distribution; (c) High Ambient Conditions: Elevated temperatures or obstructed ventilation hindering heat dissipation; (d) Power Supply Issues: Voltage or current imbalances in the power supply affecting motor performance; (e) Ground Fault: Faulty insulation causing leakage of current to the motor's ground; (f) Overload and Under Voltage: Excessive load or insufficient voltage straining the motor; (g) Under Frequency/Under Speed: Low frequency or speed affecting motor operation. This project focuses on simulating and addressing faults (a), (d), (f), and (g) using a PLC-based protection system.

### 1.2 PLC and SCADA

PLCs (Programmable Logic Controllers) are specialized industrial computers designed to automate and control manufacturing processes, machinery, and production lines. They consist of a central processing unit (CPU), input/output modules, and a programming device. The CPU acts as the PLC's brain, processing data and executing programs. Input modules receive signals from sensors, while output modules send signals to actuators. The programming device creates control programs, typically written in ladder logic, a graphical programming language. PLCs are robust, reliable, and capable of real-time processing, fault detection, and redundancy. They are widely used in various applications, including traffic lights, conveyor belts, automotive manufacturing, and food processing. PLCs have become indispensable tools for modern industrial automation.

SCADA (Supervisory Control and Data Acquisition) systems are used in industrial automation to supervise massive activities in a variety of industries while monitoring and controlling processes in real-

time. HMI (Human-Machine Interface), RTUs (Remote Terminal Units), and PLCs (Programmable Logic Controllers) are the three primary parts of SCADA. HMI enables operator involvement while displaying real-time data. RTUs communicate with sensors and other equipment to deliver data to PLCs, which use the data to carry out control procedures. Real-time data from SCADA is available to operators for process monitoring and decision-making. In order to analyse and improve processes, it also retains previous data. SCADA systems are essential for advanced data processing, real-time data collecting, monitoring, and control. They are vital to the automation of current industrial processes because of their capacity to manage complicated processes.

PLC and SCADA systems are essential to industrial automation because they increase output, cut costs, and boost overall industrial effectiveness. Numerous problems, including rotor, stator, bearing, and load faults, can occur in induction motors. A popular technique for locating faults is the examination of the spectral signature of the stator current. Physical characteristics including vibration, noise, torque, and temperature are measured via sensors. PLCs are essential for shielding induction motors from these flaws. For ladder programming and simulation tasks in this project, we will utilize the Machine\_Expert\_Basic\_V1\_2\_SP1 software. In this project, we will implement INDUSOFT WEB STUDIO SCADA.

### 1.3 Ladder Programming

Ladder logic, also known as ladder diagram or LD, is a graphical programming language specifically designed for programming Programmable Logic Controllers (PLCs). It utilizes symbolic notations to represent logic operations, with rungs of logic resembling a ladder, hence the name 'Ladder Logic'. This visual representation effectively displays the logical connection between inputs and outputs, akin to contacts and coils in a hardwired electromechanical relay circuit.

### 1.4 Automation Studio

Automation Studio, developed by Famic Technologies, is a comprehensive software tool for designing, simulating, and troubleshooting automation systems. It enables users to create detailed models of hydraulic, pneumatic, electrical, and mechanical systems, simulating their behavior under various conditions. Automation Studio's extensive library of components and tools facilitates efficient system creation and testing.

### 1.5 Proximity Sensor

A proximity sensor is a non-contact device that detects nearby objects without physical contact, primarily used in industrial and automation applications for distance and motion detection.

### 1.6 Induction Motor

Induction motors are a type of electric motor that operates using a rotating magnetic field. They are widely employed in industrial machinery, household appliances, and HVAC systems.

An induction motor consists of two main components: the stator and the rotor. The stationary stator houses stator windings, which, when supplied with AC voltage, generate a rotating magnetic field. The rotor, the rotating part, contains rotor conductors short-circuited by an end ring. When the stator's rotating magnetic field interacts with the rotor conductors, electromagnetic induction generates a current in the rotor, causing it to rotate due to electromagnetic force. Induction motors are known for their simple, efficient design, reliability, and low maintenance costs due to the absence of brushes and commutators. Their speed depends on the frequency of the supplied voltage, which can be a limitation in certain applications. Induction motors are versatile and widely used electric motors, offering efficient and reliable performance in various household and industrial settings.

## 2. METHODOLOGY

The proposed protection system, as depicted in a block diagram, encompasses voltage and current measurements, winding temperature monitoring, and rotor speed tracking. This system can be divided

into three functional groups: hardware, measurement, and software. The specific roles of each group are elaborated in the subsequent sections [5].

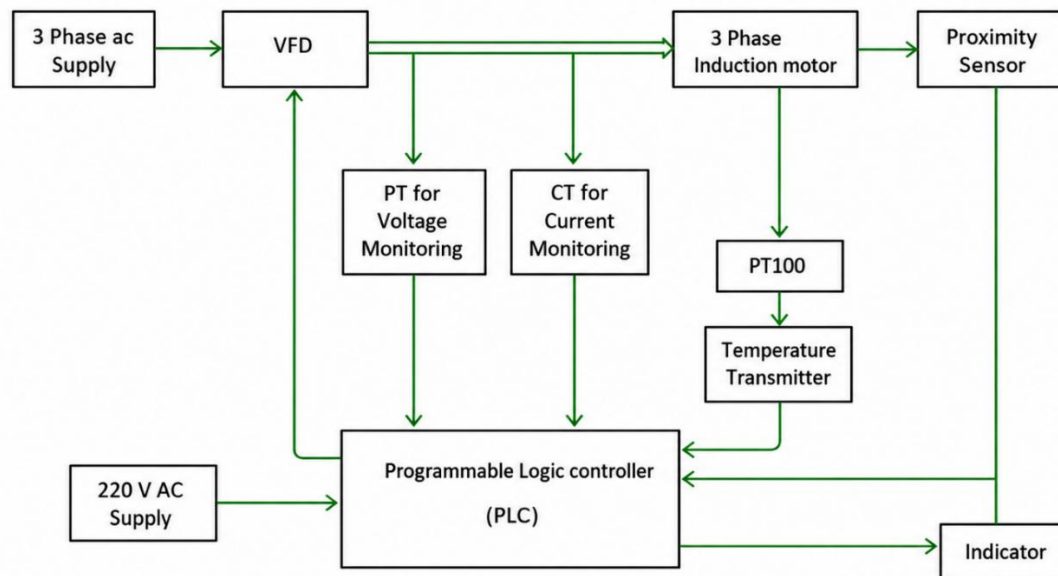

Figure 1. Block Diagram of the Purposed Project

## 2.1 Measurement

Various methods can be employed for identifying motor faults using a PLC. These include:

### 2.1.1 Speed Measurement using a Proximity Sensor

This non-contact sensor detects nearby objects by emitting an electromagnetic field and monitoring changes in the field or a return signal. The sensor measures the induction motor's speed and relays the information to the PLC.

### 2.1.2 Temperature Measurement using a PT100 Sensor

PT100 sensors, also known as resistance thermometers, utilize platinum (Pt) as the sensing element. The '100' in PT100 indicates that at 0°C, the sensor has a resistance of 100 ohms ( $\Omega$ ). The table below shows the numerical values of a Pt100 (385) temperature vs. resistance at a few points:

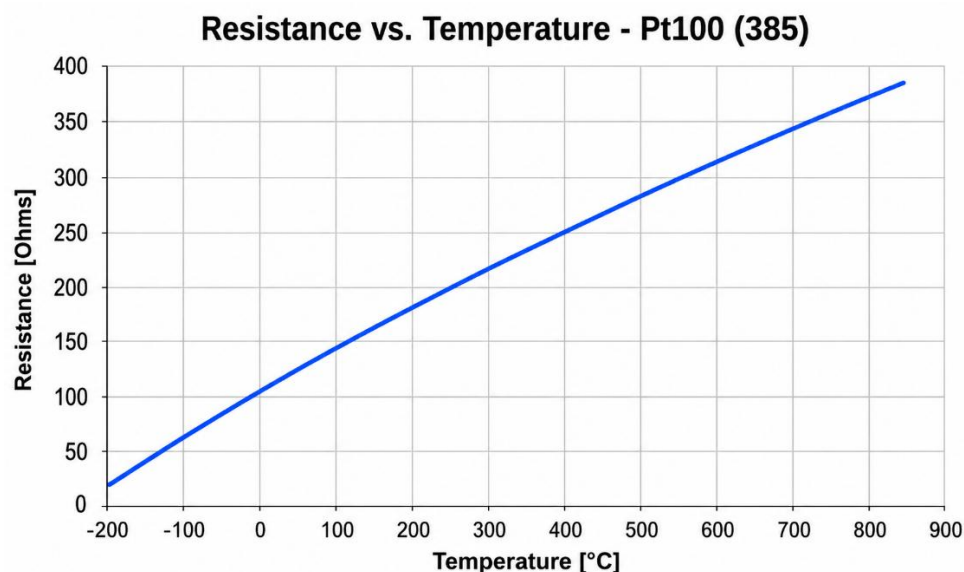

Figure 2. Resistance vs Temperature Graph

For Class B insulation, the temperature threshold is 120°C. Using interpolation techniques, the corresponding mA value is calculated as 8.876 mA. To accommodate better analog input values in the PLC, this value is multiplied by 1000, resulting in a PLC input value of 8876.

### 2.1.3 Potential Transformer (PT)

This instrument transformer accurately measures high voltage levels, stepping down the voltage for easier measurement and monitoring. It protects three-phase devices against overvoltage, undervoltage, and unbalanced voltage conditions.

The system is designed to automatically de-energize if the voltage falls below a predetermined threshold. The PT ratio is 100:1, indicating that the output voltage is 1/100<sup>th</sup> of the input voltage. The overvoltage threshold is set at 400V, and the analog input range is 0-10V. Therefore, the PT output for 400V is 4V. The PLC interprets analog input values by multiplying the input by 1000. Consequently, the analog input corresponding to the threshold is  $4 * 1000 = 4000$ . When the voltage exceeds 400V, the motor will be turned off, and the fault indicator will illuminate. In this setup, analog input is provided through a potentiometer. For simulation purposes, analog values are input using a remote slider.

### 2.1.4 Current Transformer (CT)

This instrument transformer measures the current flowing through a high-voltage conductor without direct contact. It is used in power transmission and distribution systems for monitoring and protecting electrical equipment. CTs can reduce high currents to lower levels for easier measurement. They provide mechanical protection against jam-ups or overloading conditions that increase motor current.

The CT ratio of 1000:1 indicates that the output current is 1/1000<sup>th</sup> of the input current. The overcurrent threshold is set at 1.8 Amps (1800 mA). When the input current reaches 1.8 Amps, the CT output will be 1.8 mA. The analog input range is 0-20 mA, and the PLC interprets analog input values by multiplying the input by 1000. Therefore, the analog input corresponding to the threshold is  $1.8 * 1000 = 1800$ . If the current exceeds 1.8 Amps, the motor will be turned off, and the fault indicator will illuminate.

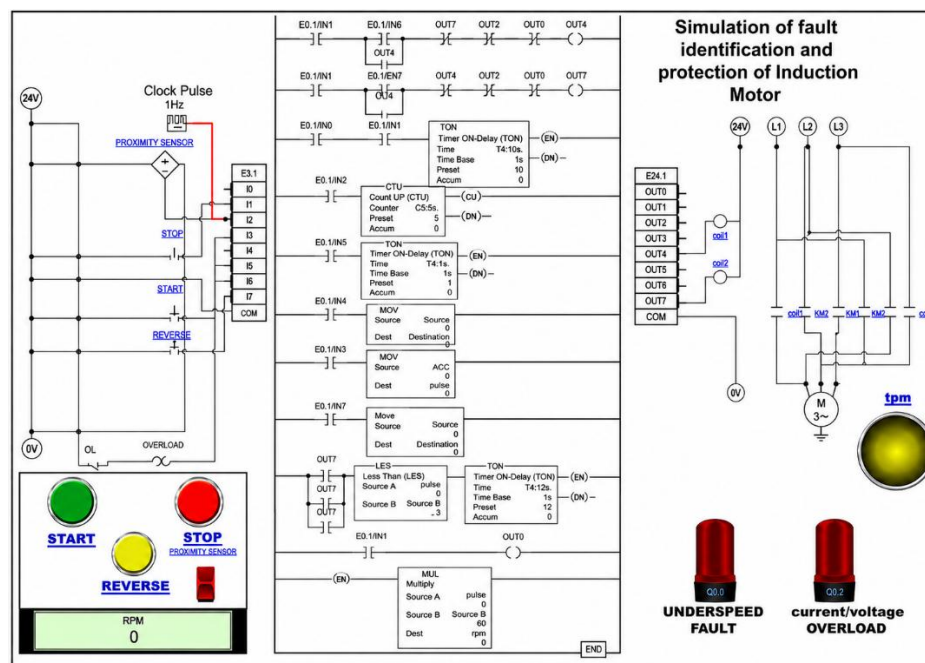

Figure 3. Simulation of Motor Protection in Automation Studio

## 2.2 Simulation for Motor Protection in Automation Studio

Automation Studio, developed by Famic Technologies Inc., is a software designed for circuit design, simulation, and project documentation of fluid power and electrical systems. This versatile tool

serves various purposes, including computer-aided design (CAD), maintenance, and training, and is widely utilized by engineers, trainers, and personnel involved in service and maintenance.

### 2.3 Schneider Logic Simulation

The Schneider logic simulation utilizes various rungs to monitor and control motor operation, implementing protective measures against under-speed, thermal overload, overvoltage, and overcurrent conditions.

#### I. Under-Speed Fault: Rungs 0-5 handle motor start/stop, data storage, RPM calculation, and under-speed detection.

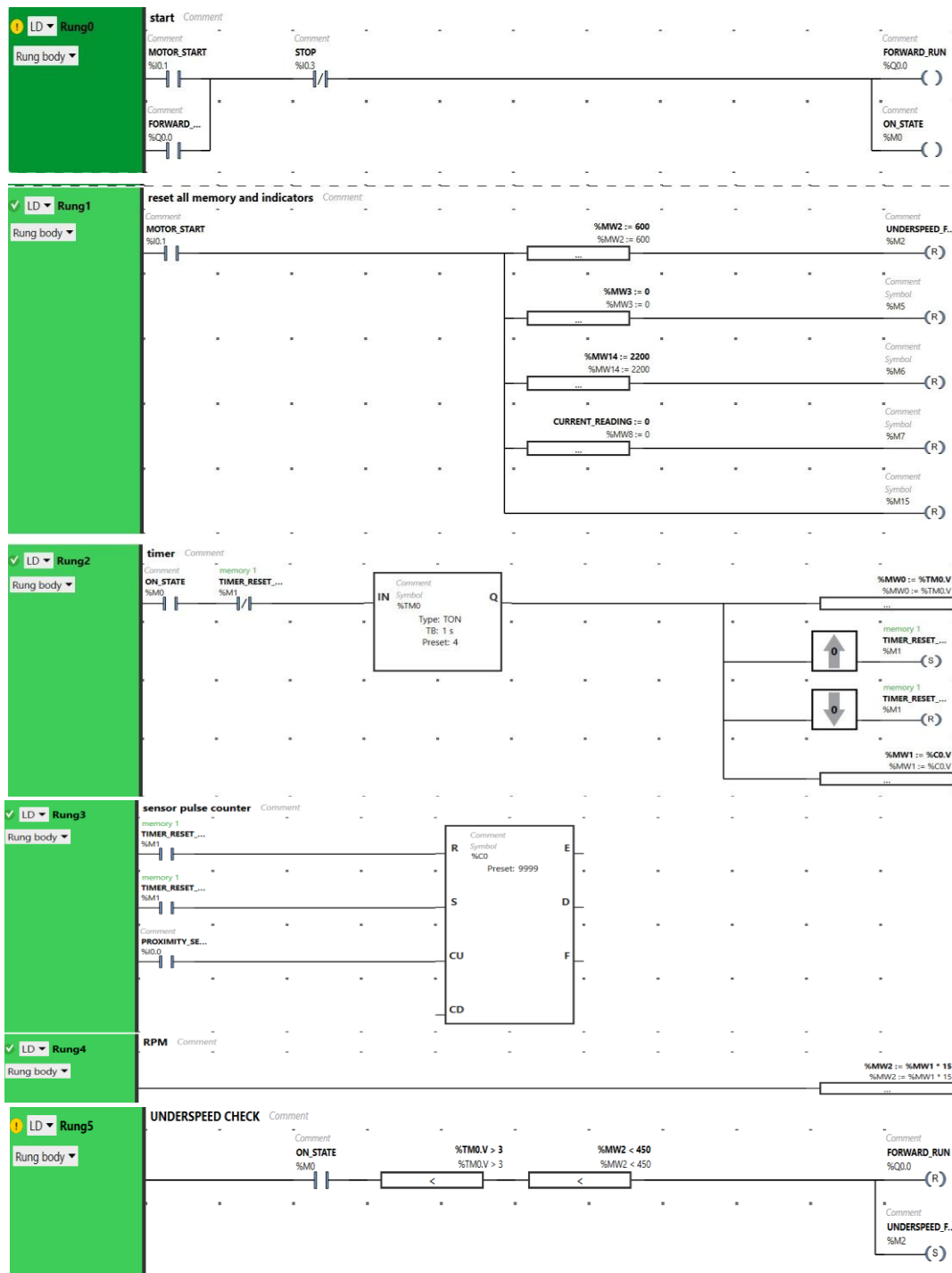

Figure 4. Ladder Logic of Under Speed Fault

**II. Thermal Overload:** Rungs 6-7 manage temperature input from PT100 and thermal overload check.

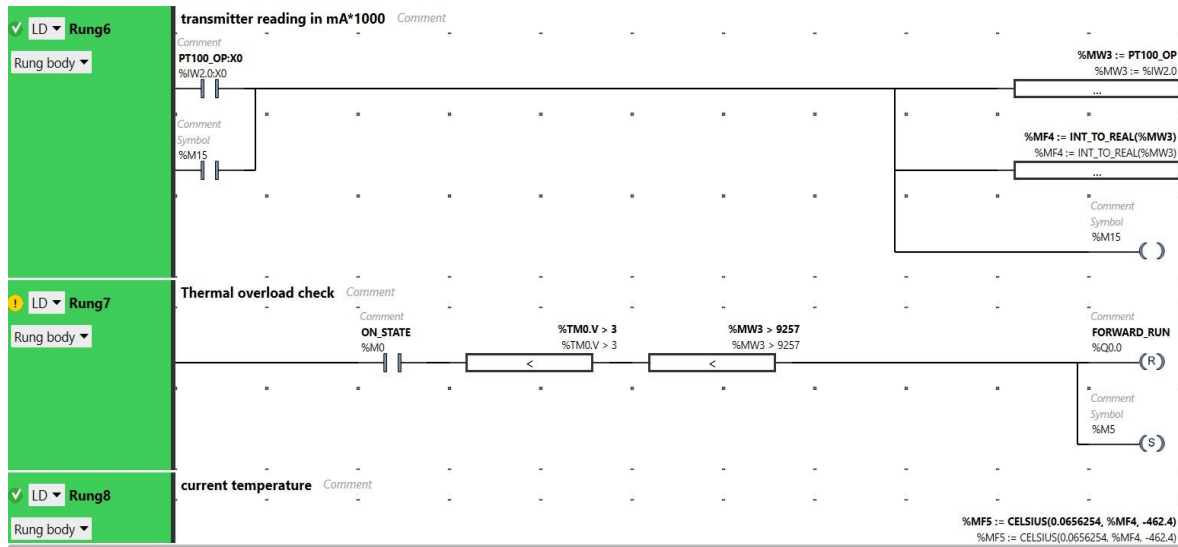

Figure 5. Ladder Logic of Thermal Overload

**III. Overvoltage:** Rungs 9-11 handle voltage input from PT, transient current check, and overvoltage detection.

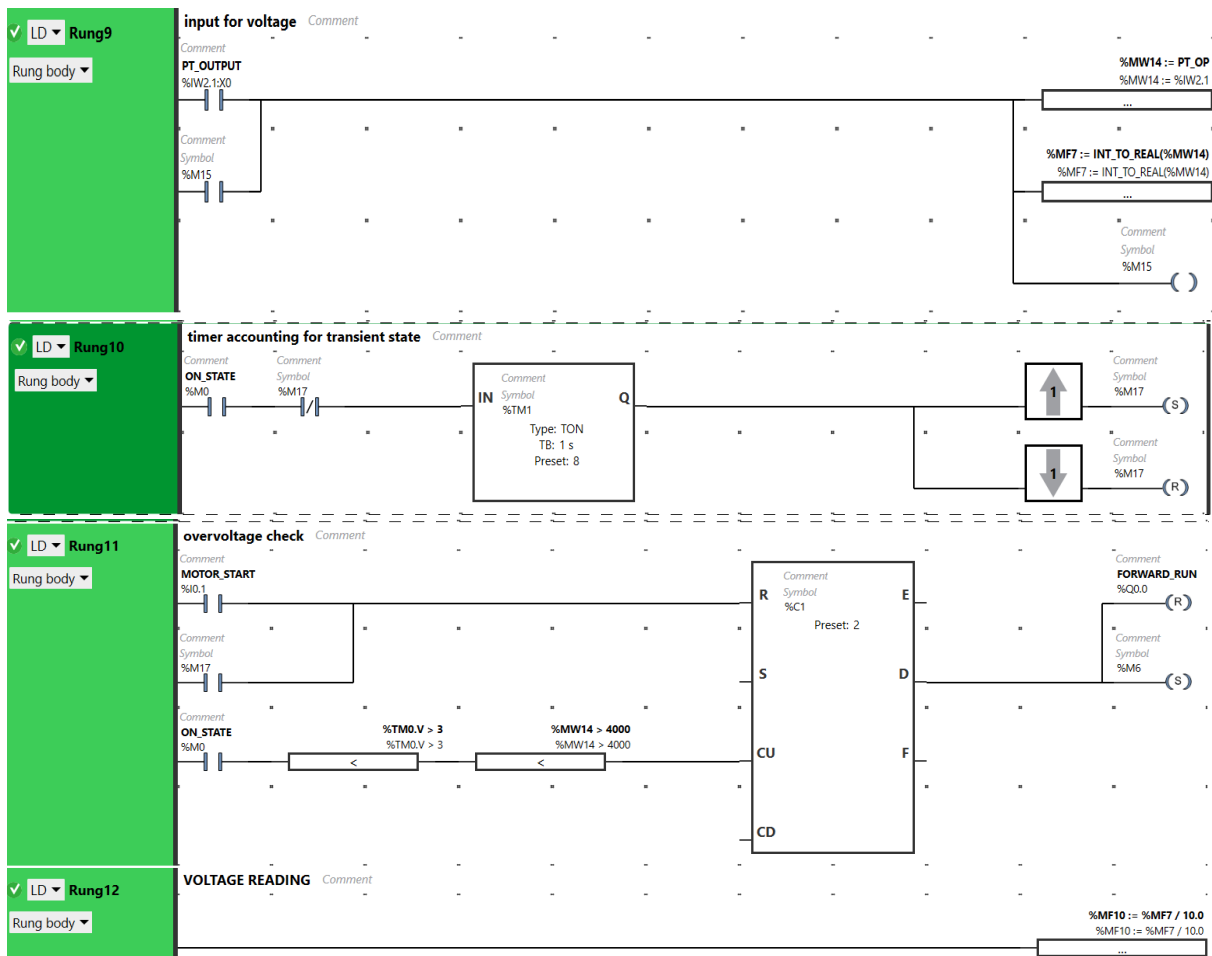

Figure 6. Ladder Logic of Overvoltage

#### IV. Overcurrent: Rungs 13-14 manage current input from CT and overcurrent detection.

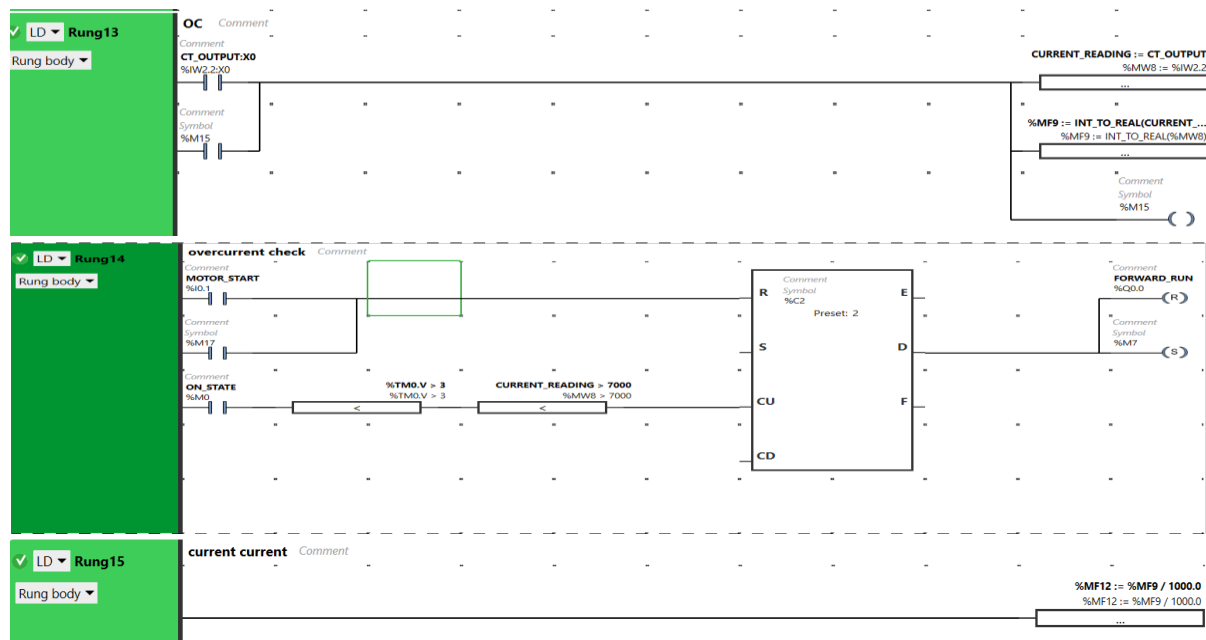

Figure 7. Ladder Logic of Overcurrent

#### 2.4 Fault Generation

Motor faults can be intentionally generated for testing purposes using two methods:

1. **Load Variation:** By overloading the motor, under-speed, overcurrent, and thermal overload faults can be induced.
2. **Variable Frequency Drive (VFD):** A VFD controls motor speed by adjusting the power supply's frequency and voltage. By altering the frequency, under-speed conditions can be simulated. Similarly, by varying the supply voltage, overvoltage and under-voltage conditions can be generated.

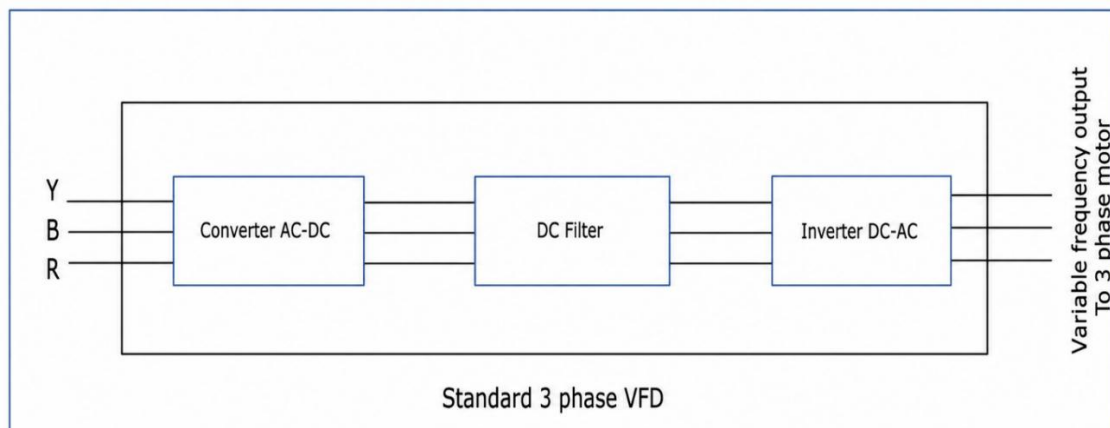

Figure 8. VFD

### 3. RESULTS AND DISCUSSION

This proposed project aims to prevent unexpected motor failures and protect against sudden shutdowns of industrial processes, enhancing safety and minimizing unplanned expenses. The PLC implementation facilitates communication, monitoring, and control of the protection system, enabling real-time data collection, transfer to a central computer, and graphical or textual information display [6].

### 3.1 Under-Speed Fault Detection and Protection

An under-speed fault is detected when the motor speed falls below the preset value of 450 rpm. The motor is turned off, and an 'US' indicator is displayed on the SCADA interface

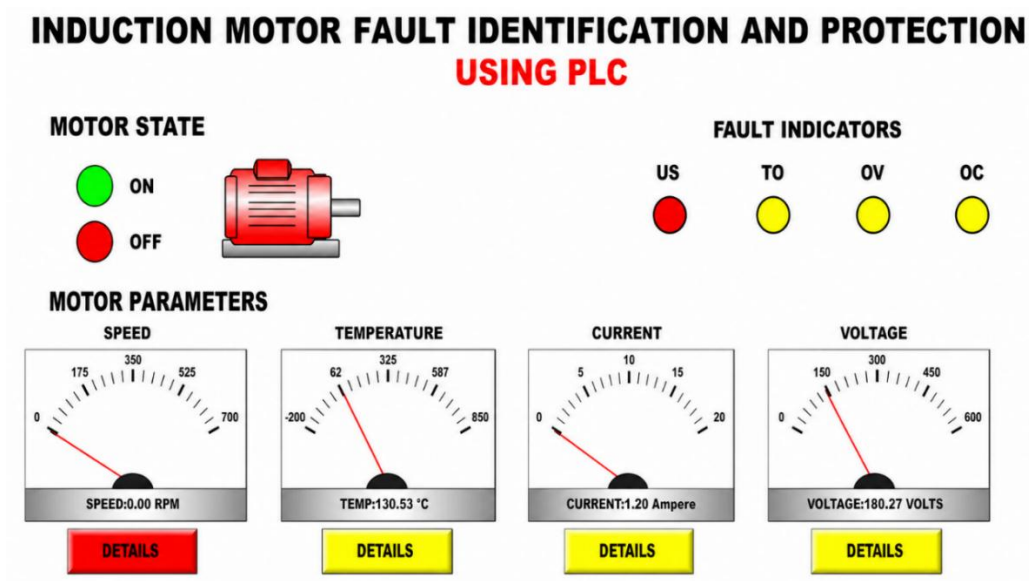

Figure 9. VFD

### 3.2 Thermal Overload Detection and Protection

A thermal overload fault is detected when the motor temperature exceeds the threshold of 120°C. The motor is turned off, and a 'TO' indicator is displayed on the SCADA interface.

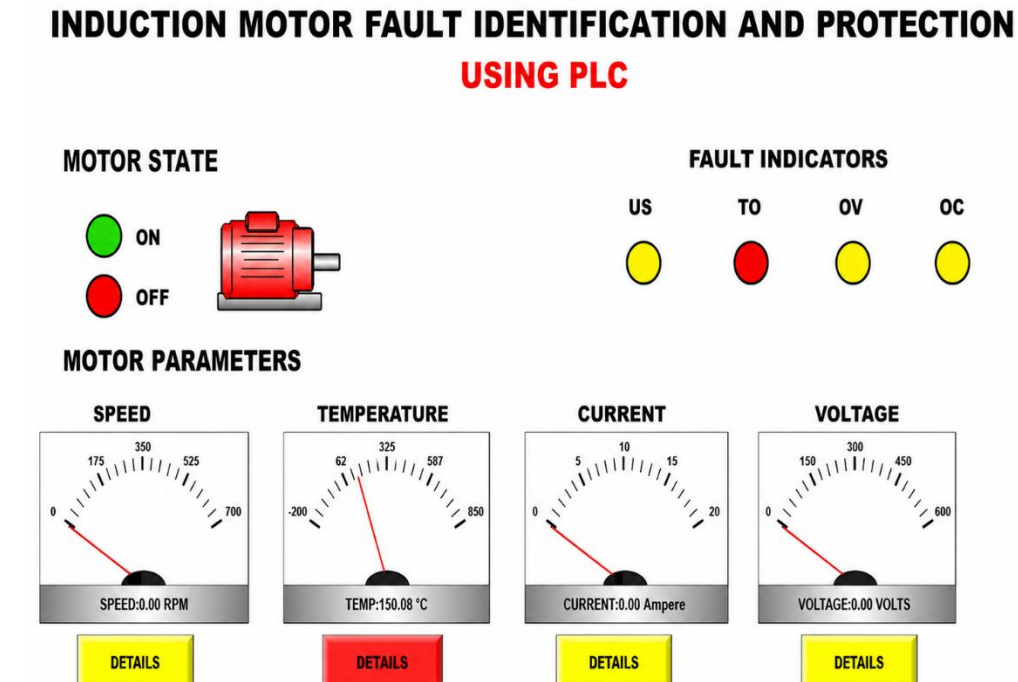

Figure 10. HMI Display Showing Thermal Overload (TO) Fault Detection in Induction Motor Protection System Using PLC

### 3.3 Overvoltage Detection and Protection

An overvoltage fault is detected when the voltage exceeds the threshold of 400V. The motor is turned off, and an 'OV' indicator is displayed on the SCADA interface.

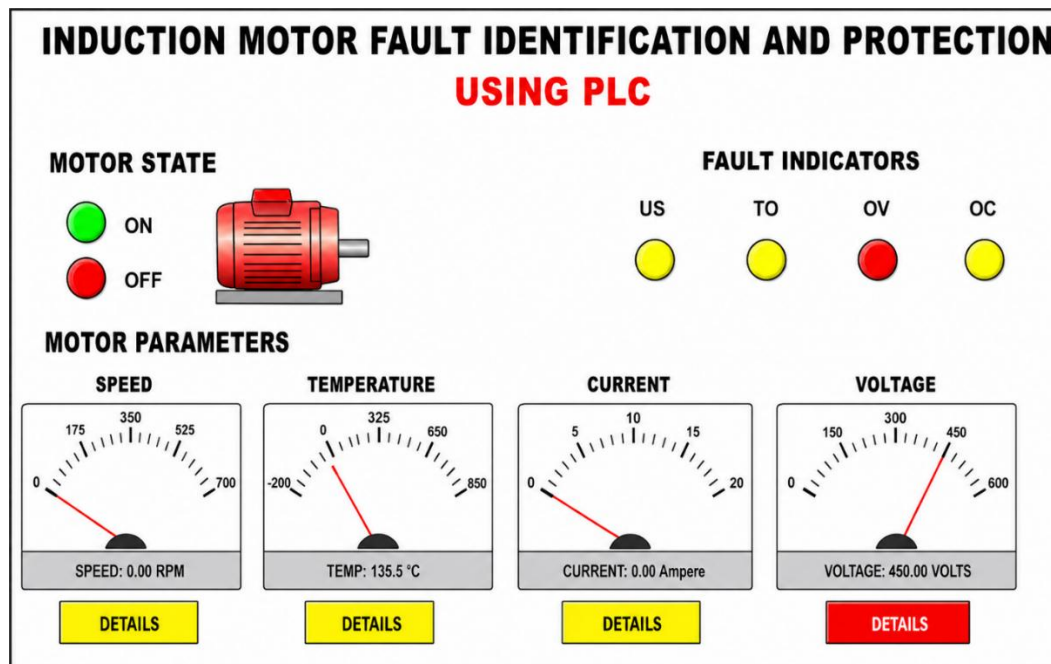

Figure 11. HMI Display Showing Over-Voltage (OV) Fault Detection in Induction Motor Protection System Using PLC

### 3.4 Overcurrent Detection and Protection

An overcurrent fault is detected when the current exceeds the threshold of 1.8 amperes. The motor is turned off, and an 'OC' indicator is displayed on the SCADA interface.

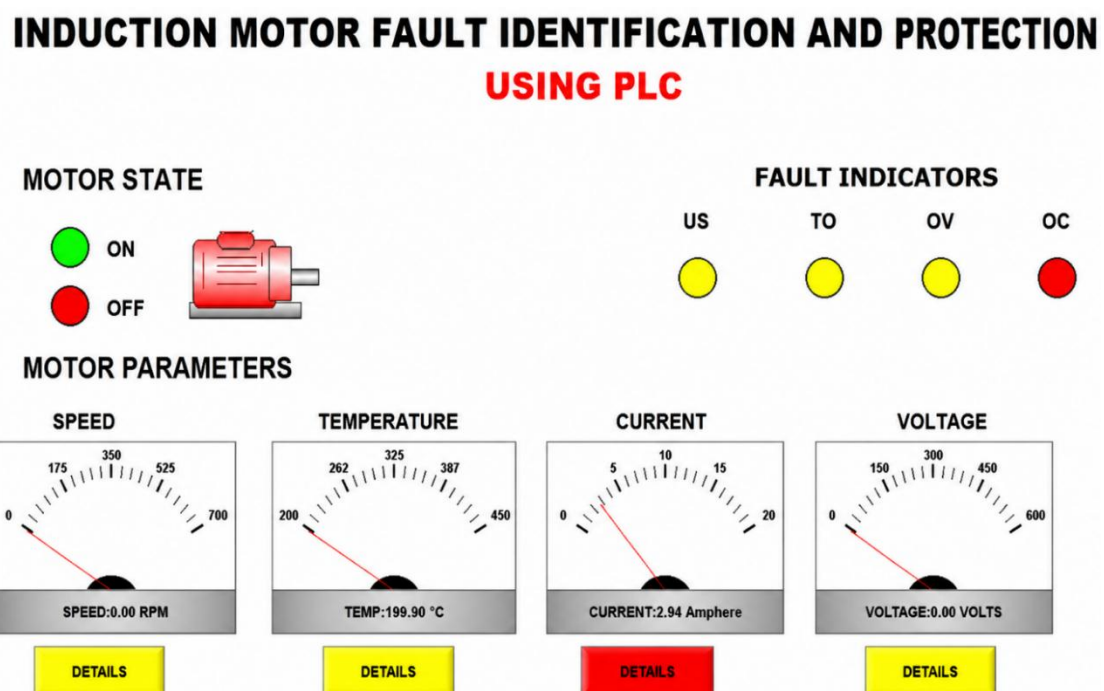

Figure 12. HMI Display of Induction Motor Fault Identification and Protection System Using PLC

## 4. CONCLUSION

This project involves designing a comprehensive protection system for induction motors, employing sensors to monitor temperature, vibrations, and speed. Current and voltage transformers are

used to measure respective parameters. If any fault is detected during motor operation, a warning message is displayed, and the motor is halted. In case of an unclear fault, the motor stops without a warning, requiring manual identification. The system has been successful in detecting and recovering from faults. Compared to conventional protection systems that rely on timers, contactors, and current/voltage relays, a PLC-based system offers significant advantages. It eliminates the need for these components and provides the operator with a visual representation of motor operation and electrical parameters.

### Acknowledgments

The authors have no specific acknowledgments to make for this research.

### Funding Information

This research received no specific grant from any funding agency in the public, commercial, or not-for-profit sectors.

### Author Contributions Statement

Name of Author	C	M	So	Va	Fo	I	R	D	O	E	Vi	Su	P	Fu
Nigam Bam Malla	✓	✓	✓	✓		✓		✓	✓	✓	✓			
Ajay KC				✓	✓	✓	✓		✓		✓	✓	✓	✓

C : Conceptualization

M : Methodology

So : Software

Va : Validation

Fo : Formal analysis

I : Investigation

R : Resources

D : Data Curation

O : Writing - Original Draft

E : Writing - Review & Editing

Vi : Visualization

Su : Supervision

P : Project administration

Fu : Funding acquisition

### Conflict of Interest Statement

The authors declare that there are no conflicts of interest regarding the publication of this paper.

### Informed Consent

All participants were informed about the purpose of the study and their voluntary consent was obtained prior to data collection.

### Ethical Approval

Not applicable.

### Data Availability

The data that support the findings of this study are available from the corresponding author upon reasonable request.



## REFERENCES

- [1] M. E. H. Benbouzid, 'A review of induction motors signature analysis as a medium for faults detection', IEEE Transactions on Industrial Electronics, vol. 47, 2000. [doi.org/10.1109/41.873206](https://doi.org/10.1109/41.873206)
- [2] G. S. Y. a. B. S. A. Siddique, "A review of stator fault monitoring techniques of induction motors," IEEE Trans. Energy Convers., Vols. vol. 20, no. 1, pp. 106-114, p. 43, 2005. [doi.org/10.1109/TEC.2004.837304](https://doi.org/10.1109/TEC.2004.837304)
- [3] M. E. H. Benbouzid, 'Bibliography on induction motors faults detection and diagnosis', IEEE Trans. Energy Convers, Vols, vol. 14, no. 4, Dec. 1999. [doi.org/10.1109/60.815029](https://doi.org/10.1109/60.815029)
- [4] I. S. İ. C. a. A. B. Ramazan Bayindir, "Fault detection and protection of induction motors using sensors," p. 43, 2008.

- [5] L. Matthias, 'Seitz Translated by ABB(China) Co', in Programmable Controller Application Tutorial[M] Beijing: Beijing Machinery Industry Press, 2009.
- [6] W. Huazhong, Supervisory Control and Data Acquisition (SCADA) system and its application. Electronic Industry Press, 2010.

**How to Cite:** Nigam Bam Malla, Ajay KC. (2024). Fault identification and protection of induction motor using PLC and SCADA. Journal of Artificial Intelligence, Machine Learning and Neural Network (JAIMLNN), 4(1), 26-37. <https://doi.org/10.55529/jaimlnn.41.27.38>

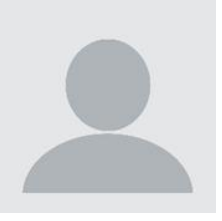
#### BIOGRAPHIES OF AUTHORS

	<p><b>Nigam Bam Malla</b>, is a researcher in the Department of Electrical Engineering at the Institute of Engineering (IOE), Paschimanchal Campus, Tribhuvan University, Nepal. His research interests include industrial automation, motor protection systems, and PLC-based control systems. He has contributed to the development of fault identification and protection systems for induction motors using PLC and SCADA technologies. Email: <a href="mailto:nigammalla@gmail.com">nigammalla@gmail.com</a></p>
	<p><b>Ajay KC</b>, is a researcher affiliated with the Department of Electrical Engineering at the Institute of Engineering (IOE), Paschimanchal Campus, Tribhuvan University, Nepal. His academic and research focus encompasses electrical machine protection, programmable logic controllers, and industrial automation systems. He has actively contributed to research on fault detection methodologies for induction motors, particularly exploring PLC-based approaches as reliable alternatives to conventional motor protection techniques in industrial environments. Email: <a href="mailto:kcajay61@gmail.com">kcajay61@gmail.com</a></p>