



Forecasting Earthquake Using Machine Learning

Allan Basilio Asma^{1*}, Peter John Berces Aranas²

^{1*}Graduate School, Polytechnic University of the Philippines, Manila, Philippines.

²School of Statistics, University of the Philippines, Diliman, Philippines.

Email: ²pjbaranas@pup.edu.ph

Corresponding Email: ^{1*}allan.asma@desfinancing.net

Received: 28 November 2023

Accepted: 14 February 2024

Published: 01 April 2024

Abstract: *Many lives and properties were lost in the past due to unforeseeable deadly earthquakes in the Philippines, which encouraged the researcher to examine different models to achieve the best model utilizing machine learning to forecast earthquakes. The researcher employed ARIMA as the baseline model for DNN, RNN, LSTM CNN, and CNN+LSTM then compared neural networks to determine which model had the lowest error using MEA - mean absolute error. After comparing the MEA from the various models, LSTM had the lowest mean absolute error, implying that it is the best model for forecasting earthquakes.*

Keywords: *Machine Learning and Neural Network DNN, CNN, RNN, LSTM and CNN+LSTM.*

1. INTRODUCTION

PHIVOLCS now manages one hundred eight seismic monitoring stations in the Philippines as of December 2020. In these stations, seismometers are installed, which detect and record earthquakes. Data is sent to the PHIVOLCS Data Receiving Center (DRC) to determine earthquake parameters such as magnitude, depth of focus, and epicenter. Once these facts are established, earthquake information and any locally reported felt intensity levels are made public. (phivolcs.dost.gov.ph).

Earthquakes have always been unpredictable, and this is still the case today. Still in jeopardy are several lives and properties. The Philippines has had 10 of the most devastating earthquakes in recorded history. The first and strongest earthquake to ever strike the Philippines occurred in 1976, with a magnitude of 7.9 in the Moro Gulf Earthquake, which sent a tsunami crashing 40 kilometers off the coast of Sultan Kudarat. An estimated 8,000 people are thought to have died or disappeared in the disaster, and another 90,000 were left homeless due to the destruction of their homes. The second it happened in 1990, when the 7.8-magnitude Luzon earthquake



affected numerous areas in Central Luzon and the Cordillera region, with Baguio City bearing the brunt of the disaster, killing about 2,000 people, and causing massive property damage. The third was the Lanao Earthquake 1955, a 7.5 magnitude tectonic earthquake that struck Lanao del Sur on April 1 and claimed 400 lives. It also damaged and destroyed wharves in Zamboanga and Pagadian and demolished homes and mosques. Fourth, the Casiguran Earthquake 1968 struck Casiguran, Aurora, and killed 270 people while damaging a small portion of the Greater Manila Area, mainly Binondo, with a magnitude of 7.3. The fifth and largest earthquake was the Bohol Earthquake in 2013, a magnitude tremor that claimed the lives of over 200 people and damaged century-old churches. It also caused extensive damage to over 79,000 residences, schools, highways, and other structures, 14,500 of which fell entirely. The sixth occurred in 1994 with the Mindanao Earthquake, which had a magnitude of 7.1 and produced tsunami waves as high as 8.5 meters. 1,530 homes were destroyed in the coastal communities of the Baco Islands and Calapan. With a 7.1 magnitude, the Panay Earthquake 1990 toppled 15% of residential homes. Additionally, churches, bridges, and governmental structures were also impacted. The damage is expected to cost PHP 30 million. The seventh earthquake, the 7-magnitude Ragay Gulf Earthquake in 1973, damaged more than 360 residential buildings, caused 14 fatalities and about 100 injuries, and was mostly felt in Luzon and Northern Visayas. The ninth was the 6.9-magnitude Negros Oriental Earthquake in 2012, which struck Cebu and the Negros Islands and killed 52 people, at least 29 of whom were buried under 30 feet of soil owing to a landslide. In the meantime, 62 people went missing, and about 112 were hurt. The 2002 Palembang earthquake was the last one.[11]

Research Elaborations

The initial step involves conducting the ARIMA (Auto Regressive Moving Average) as a baseline, in its application, each model follows separate distinct phases. Once models are calculated, the next phase is comparing their performance using metrics such as MAE mean absolute error. The goal of this study is to find the best model utilizing ARIMA as a baseline forecasting method of machine learning, which are LINEAR, DNN, LSTM, CNN, and CNN+LSTM, to forecast earthquakes in the Philippines.

2. RELATED WORK

One of the primary goals of geoscientists is to forecast the timing and magnitude of earthquakes. Using the most recent advancements in machine learning (ML), which uses computer programs that enlarge and revise themselves depending on new data, we demonstrate that we can forecast "lab quakes" in a laboratory scenario. We utilize machine learning (ML) to find telltale noises that indicate when an earthquake may happen, much like a squeaky door. The experiment closely resembles Earth faulting; therefore, in the same methodology to predict the timing but not the size of an earthquake may be successful. This strategy could be recast avalanches, landslides, and machine component failures [1].

Unprecedented levels of information are revealed in the earthquake activity by a new generation of earthquake catalogs created through supervised machine learning. The quickest way to improve earthquake forecasting may be to use unsupervised machine learning to examine the more thorough expression of seismicity in these catalogs. [2].



The Indian Subcontinent, Turkey, Greece, and Japan are among the regions that use machine learning. The model depicts the relationship between seismic information and the upcoming incidence of earthquakes. It is the arrangement that has been constructed.

To produce earthquake projections of magnitude of at least 5.0 in Japan, 4.5 in the Indian Subcontinent region, 3.7 in Turkey, and 3.2 in Greece fifteen days before the earthquakes. Compared to earlier prediction studies, the model has produced noticeably better earthquake predictions [3].

A team led by a geophysicist at New Mexico's Los Alamos National Laboratory discovered a technique that could prevent earthquake forecasting from becoming a pipe dream. The research team's strategy depends on artificial intelligence (AI) in the form of machine learning (ML), as do so many scientific pursuits nowadays. Their research uses Neural networks to mimic how our nervous system learns new things by using training data to gain expertise and understand what to watch out for. Recent success with ML has accelerated research and development in areas like seismic processing. [4].

It is possible to test neural networks and autoencoders. Another choice is 3D Convolutional Neural Networks, which incorporate the location (x-y-z) into the architecture [5].

In this study, earthquake prediction was carried out using seismic and acoustic data from a lab micro-earthquake simulation to train various Machine Learning models. From the single feature' acoustic data, which was effectively a time series, 40 statistical features, including the number of peaks, time to failure, etc. were extracted to make the forecast. This study compared accuracy in the training and testing datasets between six machine learning techniques to identify which model performed the best, including Linear Regression, Support Vector Machine, Random Forest.

Regression, Case-Based Reasoning, XGBoos, and Light Gradient Boosting Mechanism. Another stage taken into consideration for result analysis is the examination of correctness. Results from the techniques above for estimating earthquake magnitude are considerable and encouraging, indicating progress toward the most reliable forecast system possible. [6]

Unprecedented levels of information are revealed in earthquake activity by a new generation of earthquake catalogs created through supervised machine learning. The quickest way to improve earthquake forecasting may be to use unsupervised machine learning to examine the more thorough expression of seismicity in these catalogs. [7]

Seismic indicators and hybrid machine learning methodologies are used in two models for predicting earthquakes in the southern part of California. Seven seismic indicators were calculated and analytically developed from previously documented seismic occurrences in the region's earthquake database.

These indicators include the time spent during the incidence of n earthquakes (T), their typical magnitudes (M_{mean}), and the magnitude shortfall, which is the discrepancy in observed magnitudes and the magnitude shortfall and the expected magnitude (M), the slope of the



inverse Richter power law curve for n events (b), the mean square deviation for n events (σ), and $DE_{1/2}$ is the square root of the amount of energy emitted during T time.

Two hybrid machine learning techniques for forecasting earthquake magnitudes over fifteen days are given. FPA-ELM, a mix of the flower pollination algorithm (FPA) and the extreme learning machine (ELM), is the first model. FPA-LS-SVM is an FPA-LS-SVM hybrid. Root Mean Square Error (RMSE), Mean Absolute Error (MAE), Symmetric Mean Absolute Percentage Error (SMAPE), and Percent Mean Relative Error (PMRE) are the four assessment criteria used to compare and evaluate the performance of these two models. In terms of prediction accuracy, the FPA-LS-SVM model beat the FPA-ELM, LS-SVM, and ELM models, according to simulation data [8].

They are attempting to explain earthquake physics using machine learning attempting to identify earthquake warning signs. Two years ago, he and his collaborators successfully predicted earthquakes in a model laboratory system using pattern-finding algorithms similar to those powering recent developments in image and speech recognition and other types of artificial intelligence. Researchers have since matched this accomplishment in Europe.[9]

Deep learning-based approaches for earthquake prediction include Convolutional Neural Networks and Support Vector machines. The economic losses from large-magnitude earthquakes brought on by earthquakes can total millions of dollars. A global issue is the precise forecasting of large-magnitude earthquakes. Deep learning technology that can automatically extract characteristics from large amounts of data has been successfully applied in recent years to image identification, natural language processing, object recognition, etc. [10].

3. METHODOLOGY

This chapter describes the procedures utilized to conduct the research. It details the research methodology, data sources, and statistical analysis of the data.

Research Methodology

This study is based on a case study of the earthquakes that unpredictably hit the Philippines. One first needs to gather data from the PHILVOCS office to forecast earthquakes. The purpose of the data gathering is to discover essential details and correlations that might be of interest; later on, this is done by visualization of the data. The data will be aggregated into fixed periods so that the forecasting can be treated as a time series problem.

Data Collection

The dataset used was provided by DATA CUBE, consisting of different normalized tables. It includes a historical monthly magnitude from a separate area of the Philippines.

Statistical Treatment of Data

The data were examined using statistical programs like Python and SQL. The researcher performed the following techniques and statistical procedures to meet the study's objectives.



1. Different tables were logically normalized to be transferred to Data Cube.
2. Data Cube was directly connected to Python.
3. Ran Time Series Models to forecast the earthquakes.
4. Picked the most accurate model to interpret it.

The Following Statistical Tests and Analyses were also conducted

3.1 ARIMA Time Series

Methods for evaluating time series data to extract relevant statistics and other data properties to forecast future values based on previously observed values.

Multiplicative Model

The components of this notion are meant to interact rather than move independently. It is mathematically stated as $Y(t) = T(t) \times S(t) \times C(t) \times I(t)$.

Additive Model

In the additive approach, a specific observation in a time series is represented as the total of these four components. where O denotes the original data and T denote the trend. S denotes seasonal variations, C denotes cyclical variations, and I denote irregular variations.

Autoregressive model AR (P)

The AR (p) notation represents the AR model of order p and the AR (p) model's sign is betaken by $X_t = C + \sum_{i=1}^p \theta_i x_{t-i} + \varepsilon_t$ where parameters $\theta_1, \dots, \theta_p$ ($\theta_p \neq 0$), and c is a perpetual, and the arbitrary variable ε_t , is white noise. It's required to place some restrictions depending on the parameters' values to ensure it will stays in place. According to Yavuz and Gazanfer (2011), procedures in the AR (1) with $|\varphi_1| \geq 1$ are not always stationary.

Moving Average Model

The moving average model of order q is indicated by the notation MA(q):

$$X_t = \mu + \varepsilon_t + \sum_{i=1}^q \varphi_i \varepsilon_{t-i}$$

Subscript are Subscript Where μ is the expectation of X_t , $\varphi_1, \dots, \varphi_q$ ($\varphi_q \neq 0$) are the model's parameters, and $\varepsilon_t, \varepsilon_{t-1}, \dots, \varepsilon_{t-q}$, are white noise error terms.

Autoregressive Moving Average Model (ARIMA)

The p autoregressive terms and q moving-average terms are represented as ARMA (p, q). This model incorporates the AR(p) and MA(q) models.

$$X_t = C + \varepsilon_t + \sum_{i=1}^p \theta_i x_{t-i} + \sum_{i=1}^q \varphi_i \varepsilon_{t-i}$$



Autoregressive Integrated Moving Average Model (ARIMA)

According to Otoo et al. (2015) and Adhikari (2013), the ARIMA model is an extension of an ARMA model in time series analysis it is fitted the o time series to obtain a deeper understanding of the data or anticipate succeeding points in the sequence. They are employed in certain cases where data reveals non-stationarity indicators, and the lack of stationarity can be reduced using an initial differencing step.

The model is commonly known as the ARIMA (p, d, and q) model uses integer values for p, d, and q. that are not negative. that reflect the model's moving average, integrated, and autoregressive components. ARIMA modeling is an essential component of the Box-Jenkins time-series modeling method.

Box-Jenkins Methodology

George Box and Gwilym Jenkins devised a practical method for developing an ARIMA model that best fits a given time series while adhering to the parsimony principle.

The approach employs the following core iterative procedure rather than assuming any recurring trend in the preceding data from the series before casting.

- Creating differences throughout the series to achieve stationarity.
- Model Recognition
- Estimating parameters
- Diagnostic evaluation
- Using forecasting models

Autoregressive Integrated Moving Average Model (ARIMA).

To choose the most efficient ARIMA model from a large collection of models. The equation is an amalgamation of the Autoregressive AR and Moving Average MA models, and the terms have the same definitions as in the AR and MA models. $X_t = \delta + \theta_1 X_{t-1} + \theta_2 X_{t-2} + \dots + \theta_n X_n + A_t - \theta_1 A_{t-1} + \theta_2 A_{t-2} + \dots + \varphi_r A_{t-r}$

where X_t stands for the time series, A_t for white noise, $\delta = (1 - \sum_{i=1}^n \theta_i) \mu$ for the process mean, and f for the mean.

The Box-Jenkins model will the time series is thought to be stationary. To achieve stationarity, sequences that aren't stationary are adjusted or repeated multiple times. Differentiating the sequence that isn't stationary yields an ARIMA model the I stand for Integrated. Certain formulations change the sequence of deleting some series' average from each data point. As a result, a series is constructed with a mean of 0 (Brockwell and Davis, 2001).

3.2 Time Series Machine Learning

DNN - A deep neural network is an artificial neural network (ANN) with deep layers between the input and output layers. - taken from Wiki.

The main concept: We treat time-series data as a linear model: $\{X(i) \dots X(i+t)\} \sim Y(i+t+1)$.

The format demonstrates using an input time series of t steps to forecast the following step: Y (i+t+1).

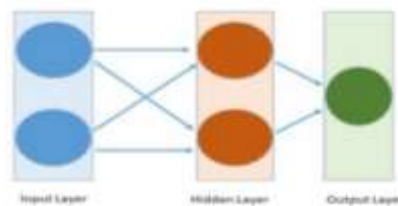
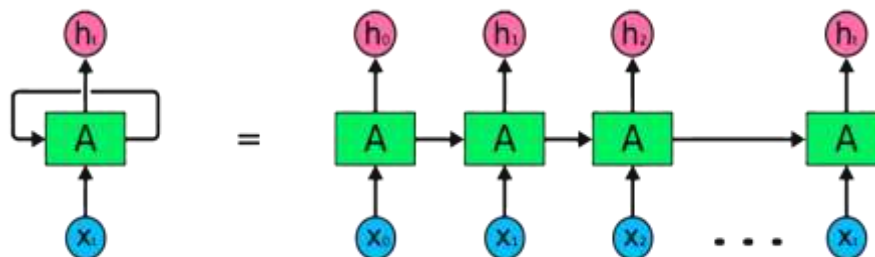

Figure 3. DNN Model[13]

RNN - is the kind of Artificial Neural Network (ANN) that Google voice search and Apple's Siri employ. Because RNNs have internal memories, they can remember past inputs, which is important for tasks like text generation, transcription, and machine translation.

A normal neural network's inputs and outputs are independent, whereas an RNN's output relies on the sequence's prior elements. Recurrent networks exchange parameters between network layers as well. Each node in a feedforward network has a different weight. In RNN, the weights and base are independently updated during gradient descent, whereas each network layer shares the same weights.

Figure 4. RNN Model [14]



LSTM is a more complex RNN designed to prevent gradient problems from deteriorating and erupting. Although the structure is different, repeating modules are present in both LSTM and RNN. LSTM has four interacting, communicative layers instead of Tanh's single layer. with one another. Machine translation, speech synthesis, speech recognition, and handwriting recognition are just a few of the sequential tasks that can benefit from LSTM's four-layered structure. You can benefit from Python LSTM for Stock Predictions tutorial to gain practical expertise with LSTM.

Figure 5. LSTM Model [15]

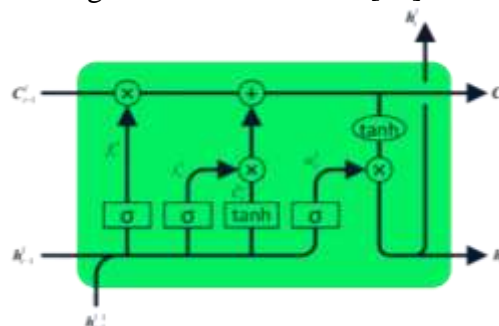

CNN is a Deep Learning system that can distinguish between objects in an input image by assigning them different attributes and weights (learnable weights and biases). A ConvNet requires far less pre-processing than conventional classification techniques. Even if filters are hand-engineered in basic approaches, ConvNets can learn these filters and attributes with enough practice.

Figure 6. CNN model [16]

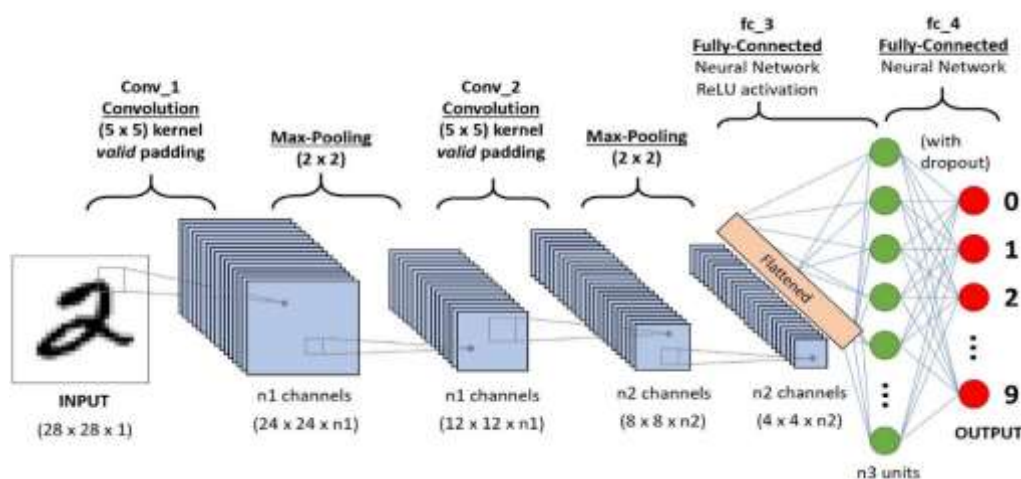

5. RESULTS/FINDINGS

To assess which model is suited to predict earthquakes the researcher utilized a hybrid time series and machine learning statistical model.

Table 1. Summary table for Accuracy Metrics – Mean Absolute Error

Model	Mean Absolute Error
ARIMA	0.3317
LINEAR	0.3611
DNN	0.2401
LSTM	0.2320
CNN	0.2710
CNN+LSTM	0.2340

Under the accuracy metrics the LSTM is the lowest mean absolute error.

Table 2. Summary table for Predicted Magnitude from August 2022 – July 2024

Year/Months	ARIMA	CNN	DNN	LINEAR	LSTM	LSTM+CNN
2022-08	5.8	5.9	5.9	6.1	5.1	5.3
2022-09	5.8	5.9	5.6	6.3	5.5	5.7
2022-10	5.7	5.4	5.9	6.1	5.8	5.9
2022-11	5.8	5.4	5.9	4.4	5.8	5.9



2022-12	5.8	6.0	5.5	5.4	5.8	5.8
2023-01	5.8	5.5	5.6	4.5	5.8	5.7
2023-02	5.8	5.3	5.4	4.9	5.7	5.6
2023-03	5.9	5.3	5.7	4.5	5.7	5.7
2023-04	5.9	5.8	5.5	6.5	5.6	5.8
2023-05	5.9	6.1	5.7	5.5	5.5	5.8
2023-06	5.9	5.8	5.7	5.2	5.5	5.7
2023-07	5.9	5.5	5.8	4.9	5.5	5.5
2023-08	5.9	5.5	5.9	5.3	5.6	5.5
2023-09	5.9	6.0	5.9	5.6	5.7	5.5
2023-10	5.9	5.3	5.8	5.2	5.7	5.5
2023-11	5.9	5.8	5.6	3.6	5.6	5.6
2023-12	5.9	5.9	5.5	3.6	5.5	5.5
2024-01	5.9	5.6	5.9	5.3	5.5	5.6
2024-02	5.9	5.9	5.6	4.4	5.5	5.6
2024-03	5.9	5.8	5.0	5.5	5.4	5.7
2024-04	5.9	6.3	5.7	8.3	5.4	5.8
2024-05	5.9	6.4	5.6	6.6	5.4	5.8
2024-06	5.9	6.0	5.7	6.0	5.5	5.6
2024-07	5.9	5.5	5.9	6.3	5.6	5.4
Highest Magnitude	5.9	6.4	5.9	8.3	5.8	5.9

The highest magnitude indicated under ARIMA model is 5.9 month of February 2022, for CNN model is 6.4 month of May 2024, for DNN model is 5.9 month of July 2024, for Linear model is 8.3 month of April 2024, for LSTM model is 5.8 month of October 2022 – January 2023, and for LSTM + CNN is 5.9 month of October – November of 2023.

The LSTM model was shown to be the best model to utilize in forecasting earthquakes in the Philippines using the ARIMA time series baseline forecasting approach of machine learning models. The chosen model can assist in mitigating potential damage and casualties.

6. CONCLUSIONS

The bases of comparison in the model use the Mean Average Error to uniform the bases for forecasted error and to make it easier to understand for the readers. The best software application to be used is Python for the ARIMA, LINEAR, DNN, LSTM, CNN, and CNN+LSTM.

Acknowledgment

The authors express their profound and unending thanks to their family, friends, loved ones, and academic colleagues for their tremendous counsel, assistance, and support in making this study a reality. Although your names were not mentioned individually, your contributions, no matter how large or small, are gratefully recognized and valued.



7. REFERENCES

1. Machine Learning Predicts Laboratory Earthquakes <https://agupubs.onlinelibrary.wiley.com/doi/full/10.1002/2017GL074677>
2. Machine learning and earthquake forecasting—next steps <https://www.nature.com/articles/s41467-021-24952-6>
3. Earthquake Magnitude Prediction Using Machine Learning Technique https://link.springer.com/chapter/10.1007/978-3-030-66763-4_4
4. Earthquake Prediction using Hybrid Machine Learning Techniques <https://thesai.org/Publications/ViewPaper?Volume=12&Issue=5&Code=IJACSA&SerialNo=78>
5. Predicting earthquakes may soon be possible with machine learning (April 21, 2022) <https://dug.com/predicting-earthquakes-may-soon-be-possible-with-machine-learning/>
6. Predicting Earthquakes using Machine Learning (September 1, 2021) <https://medium.com/marionete/predicting-earthquakes-using-machine-learning-21689435dc52>
7. <https://www.irjet.net/archives/V8/i5/IRJET-V8I5574.pdf> Earthquake Prediction using Machine Learning (May 5, 2021)
8. Earthquake Prediction using Hybrid Machine Learning Techniques (Volume 12 Issue 5, 2021.) <https://thesai.org/Publications/ViewPaper?Volume=12&Issue=5&Code=IJACSA&SerialNo=78>
9. Artificial Intelligence Takes On Earthquake Prediction (September 19, 2019) <https://www.quantamagazine.org/artificial-intelligence-takes-on-earthquake-prediction-20190919/>
10. Earthquake Magnitude Prediction Using Support Vector Machine and Convolutional Neural Network (2019). <https://scholarworks.utep.edu/dissertations/AAI22582986/>
11. Strongest Earthquake in the Philippines: 10 Most Destructive Tremors in History <https://filipiknow.net/earthquake-in-the-philippines/#1-moro-gulf-earthquake-1976>
12. The Models of Box and Jenkins https://www.researchgate.net/publication/285902264_ARIMA_The_Models_of_Box_and_Jenkins
13. DNN Image <https://medium.com/@sprhllabs/understanding-deep-learning-dnn-rnn-lstm-cnn-and-r-cnn-6602ed94dbff>
14. RNN Image <https://aditi-mittal.medium.com/understanding-rnn-and-lstm-f7cdf6dfc14e>
15. LSTM Image <https://medium.com/analytics-vidhya/exploring-different-types-of-lstms-6109bcb037c4>
16. CNN Image <https://paperswithcode.com/methods/category/convolutional-neural-networks>