Grid Synchronization Failure Detection on Sensing the Frequency and Voltage beyond the Ranges

S. Maddilety^{1*}, K. Meenendranath Reddy², S. Reshma³, Dr. P. Sankar Babu⁴,
V. Srikanth⁵

^{1*,2,3}Assistant Professor, Dept. of EEE, SVR Engineering College, Nandyal, India.

⁴Professor, Dept. of EEE, SVR Engineering College, Nandyal, India.

⁵M.Tech, SS Infotech, Hyderabad, India.

Corresponding Email: ^{1*}maddiletysuddula@gmail.com

Received: 03 February 2023

Accepted: 19 April 2023

Published: 30 May 2023

Abstract: *The goal of this project is to create a tool that can sense frequency and voltage deviations in order to identify whether an external power source has lost sync with the power grid. Hydroelectric, thermal, solar, and other forms of renewable energy are only some of the sources that feed the system and ultimately the load. These power plants must meet all grid regulations when supplying electricity. Central Electricity Agency of India Regulations of 2010 state that the system power should fluctuate by no more than 5% and that the rate of operation should be kept as near to 50 Hz as possible while not exceeding the range of 49.2 to 50.3 Hz in any case. Limits on voltage and frequency swings are part of these guidelines. If a feeder's voltage or current goes outside the safe range for the grid, the feeder must be isolated, or "islanded," from the rest of the system. This avoids widespread power interruptions of any kind. To prevent a total collapse of the grid, it is desirable to have a mechanism that can issue a warning in advance.*

Keywords: *Arduino, Power Supply, ESP 8266, Buzzer, Relays, Potentiometer.*

1. INTRODUCTION

Western, Eastern, North-Eastern, Southern, and Northern are the five national grids that make up India. The northern, eastern, north-eastern, and western grids, as well as the southern grid, are all in sync with one another. Electricity is becoming an integral component of our daily lives and a need for modern civilization. Several emerging practises have already been implemented in the power grid. Microgrids, megagrids, a plethora of sensors, data processing, visualisation tools, etc., are all part of this plan to upgrade the current grid. Voltage, frequency, and the phase angle among voltage and current are the three characteristics we've settled on for ensuring that every power plant is in sync with the State

and National power grid. In the event that any of these requirements are not satisfied, the power plant will experience a condition known as "islanding," in which it is unable to maintain synchrony with the rest of the grid. An islanding condition exists when a portion of the electrical grid remains powered by a source other than the central utility. Damage to the grid or linked equipment, as well as the safety of the maintenance workers who maintain the grid, might result from an islanding situation. Therefore, islanding states must be detected and terminated within 2 seconds, as per the IEEE1547 standard. Islanding may be detected using a wide variety of techniques.

System Components

A. Power Supply:

The purpose of these power supplies is to reduce the voltage of the AC mains energy so that it may be used by electronic circuits as well as other devices. Each component of a power supply serves a specific purpose and may be analysed independently. The regulated electrical supply takes in alternating current and outputs a stable direct current. See an example of a typical regulating DC power supply's block diagram in the image below.

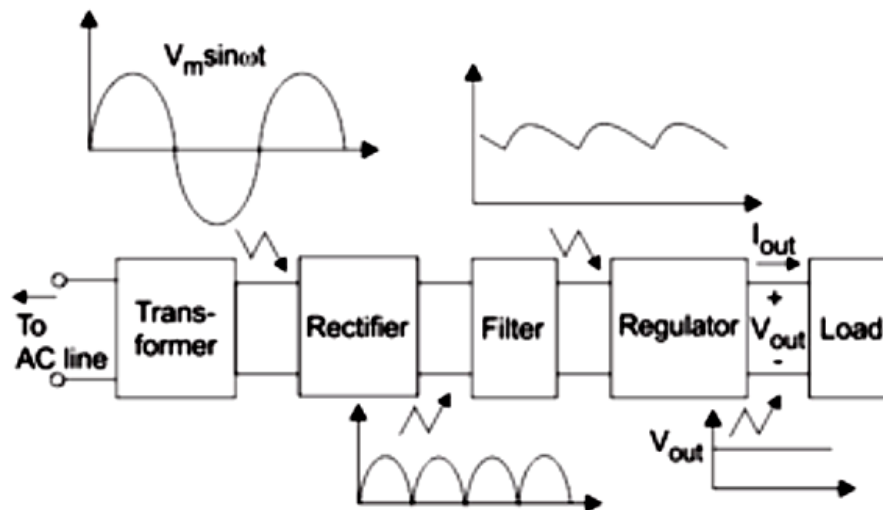

B. ESP 8266:

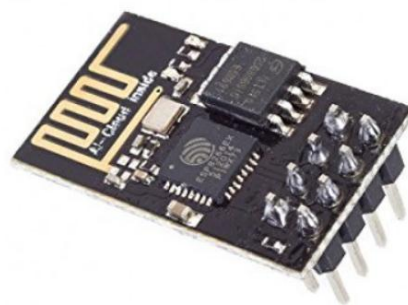

Dramatic Solutions in Shanghai, China produces the ESP8266, a low-cost Wi-Fi microprocessor with a full TCP/IP stack with microcontroller functionality. In August of

2014, the ESP-01 unit by Ai-Thinker, a third-party vendor, brought the chip to the notice of US manufacturers. With this little module, microcontrollers may establish TCP/IP connections across a wireless network with the use of standard Hayes-style instructions. At initially, however, very little information was available in English about the chip & the orders it could understand. Many hackers were drawn to the module, chip, and software, as well as the translation of the Chinese records, because to its low cost with the fact so it had very few outside parts on it, indicating that it may someday be extremely affordable in bulk.

C. Buzzer:



Mechanical, electromechanical, or electrical systems can all produce audible signals known as buzzers or beepers. Alarms, schedules, & verification of actions like mouse clicks and keystrokes are just some of the common applications for buzzers and beepers.

D. Arduino:



The Arduino Uno is the most widely used board in the Arduino family. When people talk about an Arduino, they usually mean this board. The Uno is a wonderful option for those just getting started with Arduino. There have been several iterations of the Arduino Uno, and we've included information about the most recent one (Rev3 or R3) below.

The Arduino Uno is an ATmega328-based microcontroller board. It is equipped with a reset button, a USB port, a power connector, an ICSP header, and 14 digital I/O pins (6 of which may be utilised as PWM outputs).

E. Relays:



We all know that relays are crucial to the proper operation of most sophisticated machinery. Relays are straightforward switches that may be toggled in either an electrical or mechanical fashion. An electromagnet and a set of contacts make up a relay. The electromagnet is used for the switching process. It works on a number of different principles. However, their uses are different. Relays are utilised by the majority of the gadgets.

F. Potentiometer:



A potentiometer is a variable voltage divider consisting of a three-terminal resistor with a moving or revolving contact. If only the wiper and one end terminal are connected, it functions as a rheostat, a type of variable resistor. Potentiometers are commonly used to measure electric potential (voltage), and the corresponding component is an application of this idea. Potentiometers are widely utilised as volume controllers in music equipment and other electrical devices. As an example of a device that uses potentiometers as position transducers, consider a joystick. Since the amount of energy consumed in the potentiometer will be equivalent to the power in the regulated load, potentiometers are rarely utilised for direct control of considerable power (greater than a watt).

Proposed System

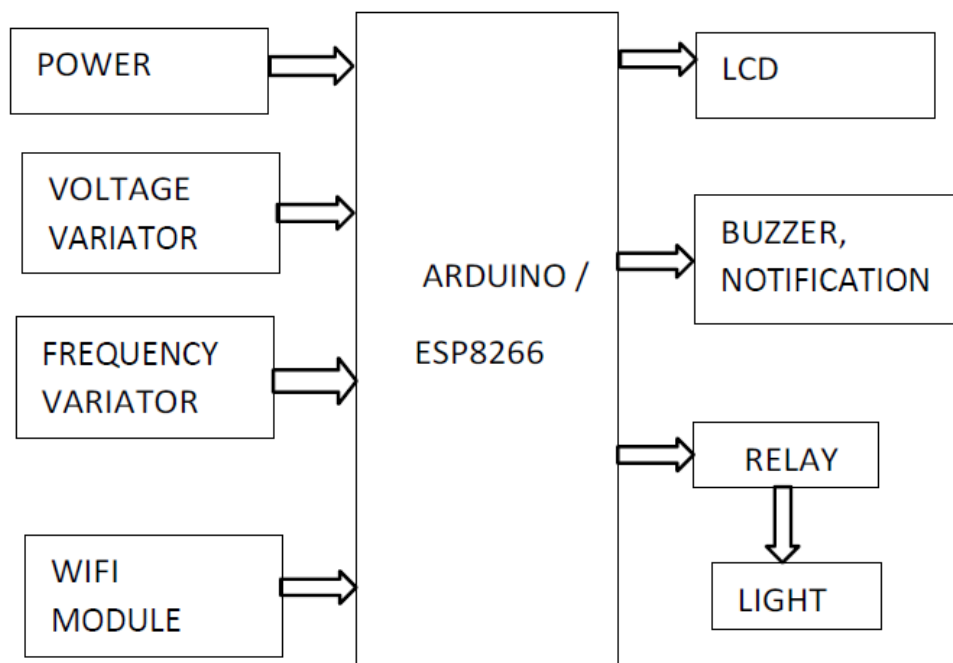

The main purpose of islanding a grid is to control two variables. Voltage and frequency are two such variables. We've used a 555 timer in free-running, stable mode, where the frequency is controlled by R, because we can't alter the timing in any other way. Because the programme has to be able to test an exact 52Hz, 50 KHz, or 49 KHz, we utilise a 555 timer. The code is set up so that the MC's outputs will go high and cause the appropriate load to be switched "ON" or "OFF" to signify islanding if the frequency of the 555 timer's output, which is fed into the MC, drops below 48 KHz or rises above 52Hz. (Related to the frequency with which they occur). In a normal condition, when the voltage is stable and the frequency is 50 Hz, neither the led nor the bulb will light up. If the grid is out of sync in any way, whether it be power or frequency, the led and bulb will light up. The microcontroller's output is linked to a relay that can turn on or off a load depending on whether the frequency is low or high, and the programme is written such that the LCD screen displays the appropriate information in either instance.

We were able to effectively implement the circuit. When we turn on the switch, the transformer reduces the voltage from 240 to 12 volts. This 12V is now being used to power the rectifier circuit that generates the adjustable dc current. The 7805 voltage regulator, which supplies 5V to the circuitry, receives 12V of fluctuating dc. In order to measure three different variables, this varying DC is sent to a voltage and frequency comparator. The microcontroller receives the measured values and processes them accordingly. In order to make adjustments, the sliding switch must be moved to the "manual" setting. Changes in voltage and frequency may be made by adjusting the POT's (potentiometer's) variable

resistance. If the voltage is steady, the LCD will show that, and if it isn't, the bulb will light up (the ideal range for household voltage is between 220 and 250 volts).

2. RESULTS

Our project calls for a frequency of 35 hertz and a voltage range of 150v–250v in order to synchronise a producing station with the grid. When the input voltage drops below 150v or rises beyond 250v, the load is turned off immediately. The load is immediately cut off if the frequency drops below 35 Hz. Since the likelihood of such high frequencies is negligible, we tend to disregard them.

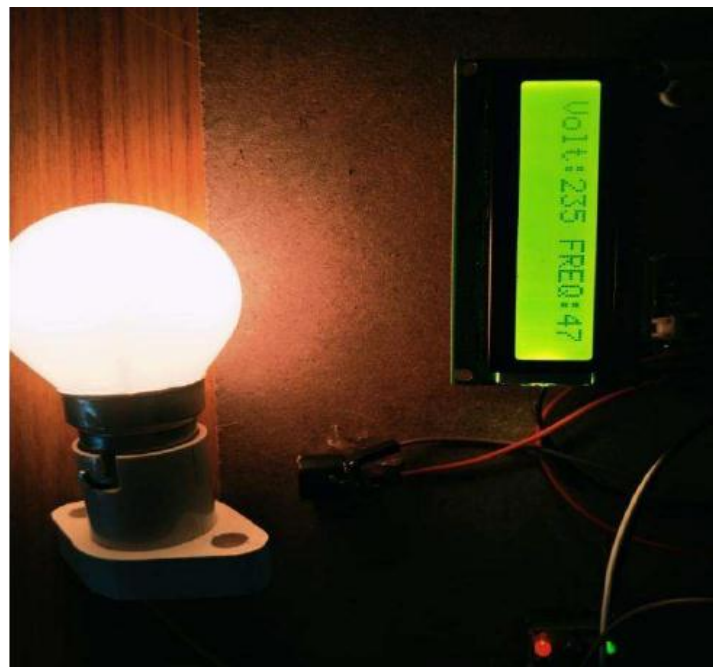

The level of voltage is 235v and the frequency is 47 Hz, those are at synchronization condition, so that the load is ON and the buzzer is OFF.

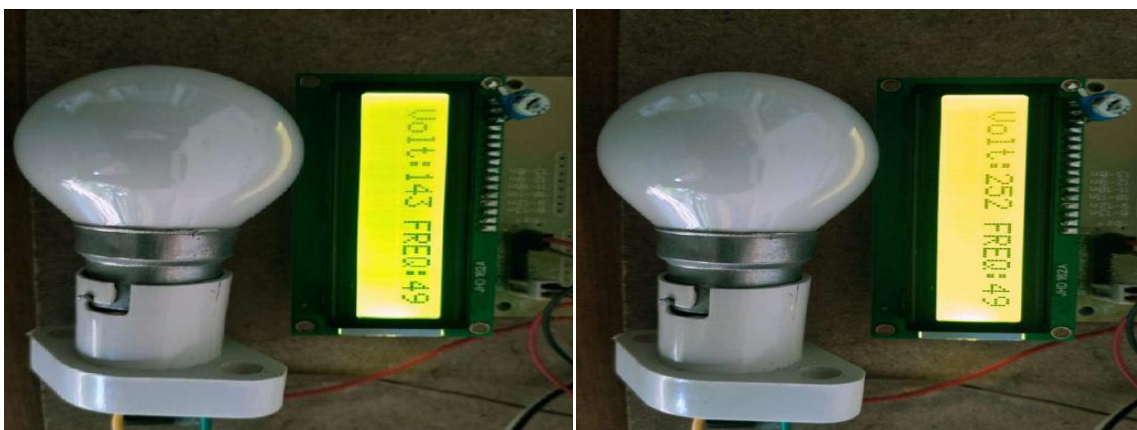



3. CONCLUSION

The goal is to create a system that can sense frequency and voltage deviations to identify when an external power source has lost synchronisation with the power grid. Power comes from a variety of sources, including hydrothermal, solar, and other units connected to the grid. In order to power the load. Grid regulations include a requirement to keep voltage and frequency swings under control. The same feeder must be immediately cut off if the grid's tolerance for variation is exceeded. By detecting fluctuations in voltage and frequency, this prevents widespread power outages. In this seminar, we'll be using the microcontroller ATmega328, which, with a bit of tweaking to the code, can do a lot of useful things. In case the Grid completely goes down, it is important to have backup plans ready.

4. REFERENCES

1. Zongjie Liu, Lifeng Zhu, Li Deng, Lijun Qin, Feng Jiao, "The Research of Islanding Detection about the Photovoltaic Grid-Connected Generation System"- International Journal of Computer and Electrical Engineering, Vol. 5, No. 3, June 2013.
2. Karan Gupta, Shreyas Gupta, Kummad Verma, Anil Singh, Abhimanou Sharma, "Detecting Power Grid Synchronization Failure on Sensing Bad Voltage or Frequency Documentation"-International Journal of Engineering Research and General Science, Volume 4, Issue 2, March- April, 2016.
3. Laukik S. Raut, Shahrukh B. Pathan, Gaurav N. Pawar, Mandar V. Pathak, "Detecting Power Grid Synchronization Failure on Sensing Frequency or Voltage beyond Acceptable Range"- International Journal of Research in Advent Technology, Vol.4, No.4, April 2016.
4. Rohan Solanki, Divyesh Patel, YuvrajGharia, Daivik Sailor, Bhumit Patel, Ashish Chaudhari, "Detection And Protection of power grid synchronisation failure"-



- International Research Journal of Engineering and Technology, Volume 03, Issue: 05, May-2016.
5. Pankaj Singh, Anuj Sharma, ShubhamSaha, Anshul Chauhan, Amit Verma, “POWER GRID SYNCHRONIZATION FAILURE DETECTION AND RECOVERY”- International Journal of Research in Engineering and Technology, Volume: 05, Issue: 03, Mar-2016.
 6. Ajit S Gaikwad, Ch. Malla Reddy, Pravin S Gulhane, “Developing Islanding Detection Arrangement for Grid on Sensing Voltage or Frequency Variation”- International Journal of Innovative Research in Electrical, Electronics, Instrumentation and Control Engineering, Vol. 3, Issue 7, July 2015.